

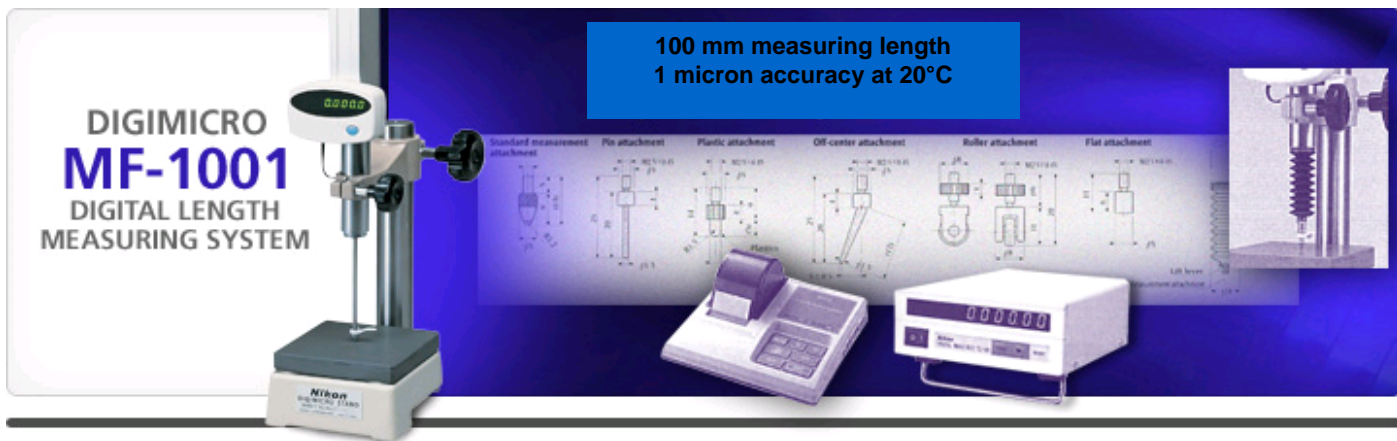

Nikon high precision 100mm digital height gage





Nikon high precision 100mm digital height gage

Easy-to-operate, superior performance photoelectric digital counter.

The MF-1001 is a compact digital micrometer offering flawless contact measurements of dimensions, thickness and depth. It features a measuring length equal to 100mm and accuracy of 1µm at 20° C. Stands are available in ceramic, steel or granite for added stability and a wide variety of probe tips are available to suit most applications.

Highlights

- Measuring length equal to 100mm
- Accuracy of 1 micron at 20°C
- Readings as small as 0.1 µm or even 0.01 µm can be made depending on the counter
- RS-232 and printer output are standard features

Specification MF1001:	
Readout travel:	100mm
Minimum readout:	0.1 Micron (switchable determined by the counter used)
Accuracy:	
Stand Type 3	Heavy duty with unique precision 2-axis targeting adjustment knobs. Spiral column height adjustment as well as 360° tilt, swivel and rotation.
Measuring angle	Useable in down or sideways position
Measuring force - variable:	Down 125-185; Lateral 85 to 125 gf
Response speed:	500m/seconds or better
MFC-101 Compact Counter Tech Specs:	Mounting: Can be mounted directly on the Digimicro; Inches/mm: Inch or Metric (switchable); Display: 7-segment LED display; Minimum readout: 0.1, 0.5, 1.0 ,ocrpm (0.000005", 0.00002", 0.00005") setting by switch on back; Reset: Zero reset button on front; RS232: RS232 output (with optional cable); Power: 12V DC adapter - available in 120V or 240V models
TC-101 Table-top Counter Tech Specs:	Inches/mm: Inch or Metric (switchable); Display: 10-segment LED display; Minimum readout: 0.01, 0.05, 0.1, 0.5, 1.0 micron (0.0000005", 0.000002", 0.000005", 0.00002", 0.00005") dip switch on back; Functions: Zero reset button on front, preset, pulse check, zero blanking; RS232: RS232 output (with optional cable); Power: 12V DC adapter - available in 120V or 240V models; Optional: Extension cable 2M (6 ft) counter to Digimicro head



Left: standard ceramic stand for MF1001, shown with the counter (DRO) Nikon TC-101

Right: standard granite stand for the MF1001





Nikon high precision 100mm digital height gage

Nikon's most advanced photoelectric digital counter.

The MF-1001 is a compact digital micrometer offering flawless contact measurements of dimensions, thickness and depth. It features a measuring length equal to **100mm** and accuracy of 1µm at 20° C. Stands are available in ceramic, steel or granite for added stability and a wide variety of probe tips are available to suit most applications.



MFC-101 Counter

A compact, single shaft counter for exclusive use with the MF-501 and MF-1001 with display and resolution switching, direction switching, and display unit switching functions. Can be attached to the head or placed outside. RS-232C output and printer output are standard features.

	MH12-MPM	MF-501-MPM	MF-1001-MPM
Specifications			
travel range (plunger stroke)	12 mm	50 mm	100 mm
minimum resolution	1 nm	1 nm	1 nm
response speed (@ 1 nm res.)	400 mm/s	400 mm/s	400 mm/s
lifetime without degradation	> 1,000,000 cycles	> 1,000,000 cycles	> 1,000,000 cycles
Accuracy (@ 20 C +/- 1 C)			
across full travel range	700 nm or better	1 micron	3 micron
repeatability (per JIS 8.7509-8-4)	200 nm	500 nm	500 nm
return error	150 nm	500 nm	500 nm
certification & unit accuracy profile	(optional)	(optional)	(optional)
Physical Characteristics			
size (excl. plunger casing, plunger & tip)	58 x 31 x 24 mm	163 x 42 x 30 mm	274 x 42 x 30 mm
plunger casing diameter	8 mm	25 mm	25 mm
total mass	145 g	310 g	480 g
mass of moving parts	20 g	37 g	56 g
force to compress plunger spring*	0.44 to 0.64 N	0.39 to 1.42 N	0.39 to 1.42 N
operating radial force tolerance	0.981 N	0.981 N	0.981 N
operating torsion tolerance	0.0049 Nm	0.0049 Nm	0.0049 Nm
non-operating radial force tolerance	9.8 N	1.961 N	1.961 N
non-operating torsion tolerance	0.39 Nm	0.294 Nm	0.294 Nm
<i>*Default, adjustable at factory</i>			
Electrical			
operating DC voltage	5 V	5 V	5 V
USB cable supplied**	2000 +/-50 mm	2000 +/-50 mm	2000 +/-50 mm
<i>**connects to MPM300 or MPM300/OEM</i>			
Environmental			
operating temperature	20 C to 40 C	20 C to 40 C	20 C to 40 C
non-operating temperature	-20 C to 60 C	-20 C to 60 C	-20 C to 60 C
operating humidity	< 95% non-condensing	< 95% non-condensing	< 95% non-condensing
non-operating humidity	< 95% non-condensing	< 95% non-condensing	< 95% non-condensing
non-operating humidity	< 80% (@ 40 to 60 C)	< 80% (@ 40 to 60 C)	< 80% (@ 40 to 60 C)

A Reputation for Excellence

Recognized as a leader in shop-floor digital height gages, the Nikon DigiMicro product line from Nikon has established a reputation for high-precision and high reliability throughout Japan, USA, Europe and Asia. When used as position encoders in motion controls Nikon DigiMicro products fulfil some of the most demanding applications in semi-conductor and other manufacturing process systems,

In these capacities, the encoders are ideal for both laboratory motion controlled systems as well as embedded use as in robotic systems and industrial automation equipment.



Nikon high precision 100mm digital height gage

The DigiMicro Family

The DigiMicro product line from Nikon is a family of optically-based position feedback encoders. They are often used as digital height gauges but have many other uses and applications in motion control systems. The encoders feature resolution down to 5 nanometers with sub-micron accuracy, and are built with Nikon's traditional superior quality and reliability to combat harsh industrial environments.

Three models of the DigiMicro encoder heads are available from Ryf AG for the Swiss Market with measurement ranges from 12mm, 50mm up to 100mm. All models work with a mating interpolator. These plunger-type probes have extremely smooth mechanical action and feature a Nikon exclusive diffraction-type optical encoder. The encoder mechanism is enclosed in a sealed compact extruded-aluminum housing which resists contamination and dirt. The encoders install quickly, are easy to set-up, and have a wide variety of industrial and research applications.

Shop Floor, watch making or Laboratory Instruments

For shop floor and laboratory measurement instruments, Nikon DigiMicro encoder heads are used as digital height gages and are typically used with the TC-101 digital read out display. A customer can read resolutions from as small as 10 nanometers up to 5 microns. The TC-101 and other DigiMicro accessories, such as measurement stands and a variety of probe tips, are also available through Ryf Ltd for the Swiss market.

Applications

- Motion Control
- Laboratory Instruments
- Medical Equipment
- Robotics
- Industrial Automation
- Milling Machines
- Semiconductor Equipment

Features

- Nanometer Precision
- Quick easy integration
- High Reliability and Durable
- Greater than 1Million Cycle operation
- 5/12V operation
- Standard A Quad B output
- Rugged extruded aluminum enclosures

Bellows may be purchased for further protection for MF-501 and MF-1001 from dust and oil particles



Nikon MF-1001-MPM encoder

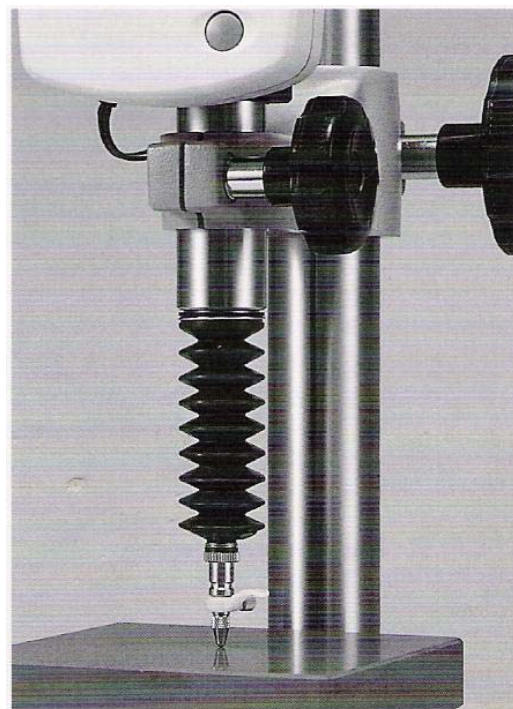

Nikon MF1001-MPM Encoder

MF-1001-MPM encoder is one of the smallest encoders from Nikon's DigiMicro product line. It employs a newly designed mechanical guide structure offering extremely smooth and precise linear motion, suitable for applications in motion control systems in nanometer scale. The encoders feature resolution down to 1 nanometer with sub-micron accuracy.

MF-1001-MPM features a Nikon exclusive diffraction-type optical encoder. The encoder mechanism is enclosed in a sealed compact extruded-aluminum housing, which resists contamination and dirt.



Nikon high precision 100mm digital height gage

DigiMicro Interpolators MF-1001

Specifications	VFU-X1600S	TC-101
digital readout display	no	yes
provides A Quad B output	yes	no
interpolation factor	1600	up to 800
minimum resolution	5 nm	10 nm
resolution settings - user adjustable	(5 nm only)	10nm, 50nm 100nm, 500nm, 1um, 5um
DigiMicro encoder heads supported	MH-12M, MF-501-5V, MF-1001-5V	MF-501, MF-1001 (12 Volt versions)
Applications & Features	best suited for real-time motion control rugged metal casing suitable for hidden industrial mounting	best suited for human read-out 10 Digits, 7-segment LED reset, preset, pulse check, error alm
Physical Characteristics		
size	126.5 x 41 x 29 mm	176 x 150 x 67 mm
mass	~ 200 g	~ 1 kg (excl. power supply)
Electrical		
output connector*	Tajimi Musen R04-R12M	RS-232 for data option
output signal (See Notes 1 & 2 below)	Digital A Quad B (pulsed 5 MHz)	Async 8 bit characters
external DC power supply included	no (to be procured by user)	yes (12 V, 2.5 A)
DC power cable length	N/A (user customized)	1 m
AC input to external power supply	N/A (user customized)	100 to 120 VAC, 50 to 60 Hz
external power supply required	+5 VDC (+/- 5% ripple)	N/A
power supply noise tolerance	+/- 50 V (50 ns/ 1us pulse)	N/A
induced noise tolerance	+/- 1 kV (50 ns/ 1us pulse)	N/A
power consumption with encoder	0.5 W (103 mA)	6 W
<i>*a mating is connector supplied with VFU</i>		
Environmental		
operating temperature	0 C to 40 C	21 C to 40 C
non-operating temperature	-20 C to 60 C	-20 C to 60 C
operating humidity	< 95% non-condensing	< 95% non-condensing
non-operating humidity	< 95% non-condensing	< 95% non-condensing
non-operating humidity	< 80% (@ 40 to 60 C)	< 80% (@ 40 to 60 C)

The encoder counter board to be connected to the VFU-X1600S A Quad B digital output should be capable of detecting faster than a 5 MHz clock edge for reliable pulse counts. The user must make the connecting cable using the supplied mating connector.



The Nikon VFU-X1600s high resolution interpolator for motion control



Nikon high precision 100mm digital height gage

Nikon DigiMicro Encoder Accessories MF-1001

Also available are a variety of DigiMicro accessories. These include several different types of probe tips which can be attached to the end of the plunger.

These plunger tips are interchangeable with many probes as offered by Ryf / Nikon as well as customer-designed probes.

