



Leica E Series

Living up to Life

ryf ag
 Ryf AG
Bettlachstrasse 2
2540 Grenchen
tel 032 654 21 00
fax 032 654 21 09
www.ryfag.ch

MICROSYSTEMS

Leica E Series – Features, specifications

Stereomicroscope	Leica ES2	Leica EZ4 10×	Leica EZ4 16×
Type of microscope	10° Greenough	10° Greenough	10° Greenough
Optical system	parfocal	parfocal	parfocal
Magnification changer	2-level, 3:1	zoom 4.4:1	zoom 4.4:1
Eyepieces for spectacle wearers	10×/20 fixed	10×/20 fixed	16×/15 fixed
Diopter correction	–	–	–
Viewing angle	60°	60°	60°
Working distance	100mm	100mm	100mm
Magnification range	10×/30×	8× to 35×	12.8× to 56×
Maximum resolution	159 Lp/mm	170 Lp/mm	170 Lp/mm
Maximum numerical aperture	0.053 nA	0.057 nA	0.057 nA
Object field diameter	20mm / 6.7mm	5.7 to 25mm	4.3 to 18.8mm
Eyecups	replaceable	replaceable	replaceable
Interpupillary distance	50 to 75mm	50 to 75mm	50 to 75mm
Beam path	100% visual	100% visual	100% visual
Focusing drive	Individually adjustable ease of movement, 75mm travel	Individually adjustable ease of movement, 75mm travel	Individually adjustable ease of movement, 75mm travel
Grip	integrated	integrated	integrated
Illumination System			
LED incident light and transmitted light	integrated, independent or combined	integrated, independent or combined, dimmable	integrated, independent or combined, dimmable
Control	On/off switch	membrane switch	membrane switch
Incident light method	angled incident light with three upper LEDs	- maximum intensity with 5 LEDs, - angled incident light with LEDs, - side light with 3 LEDs	- maximum intensity with 5 LEDs, - angled incident light with LEDs, - side light with 3 LEDs
Dimmer	–	yes, for incident and transmitted light	yes, for incident and transmitted light
Auto OFF	–	after 2 hours	after 2 hours
LED service life	approx. 25 000 hours	approx. 25 000 hours	approx. 25 000 hours
Light quality	homogeneous daylight, free of UV and IR	homogeneous daylight, free of UV and IR	homogeneous daylight, free of UV and IR
Maintenance	maintenance-free	maintenance-free	maintenance-free
Power supply	universal from 100V to 240V, voltage-sensitive, integrated	universal from 100V to 240V, voltage-sensitive, integrated	universal from 100V to 240V, voltage-sensitive, integrated

Stereomicroscope	Leica EZ4, open	Leica EZ4 HD 10×
Type of microscope	10° Greenough	10° Greenough
Optical system	parfocal	parfocal
Magnification changer	zoom 4.4:1	zoom 4.4:1
Eyepieces for spectacle wearers	replaceable, fixed or adjustable: 10×/20, 16×/16, 20×/12 not suitable for spectacle wearers	10×/20 fixed
Diopter correction	from +5 to -5 (adjustable eyepieces)	–
Viewing angle	60°	60°
Working distance	100 mm	100 mm
Magnification range fi fi fi	depending on eyepieces used: 8× to 70×	8× to 35×
Maximum resolution	170 Lp/mm	170 Lp/mm
Maximum numerical aperture	0.057 nA	0.057 nA
Object field diameter	depending on eyepieces used: 3.4 to 25 mm	5.7 to 25 mm
Eyecups	replaceable	replaceable
Interpupillary distance	50 to 75 mm	0 to 75 mm
Beam path	100% visual	50% visual and 50% video/photo
Focusing drive	individually adjustable ease of movement, 75 mm travel	individually adjustable ease of movement, 75 mm travel
Grip	integrated	integrated
Illumination system		
LED incident light and transmitted light	integrated, independent or combined, dimmable	integrated, independent or combined, dimmable
Control	membrane switch	membrane switch
Incident light method	- maximum intensity with 5 LEDs, - angled incident light with LEDs, - side light with 3 LEDs	- maximum intensity with 5 LEDs, - angled incident light with LEDs, - side light with 3 LEDs
Dimmer	yes, for incident and transmitted light	yes, for incident and transmitted
Auto OFF	after 2 hours	after 2 hours
LED service life	approx. 25 000 hours	approx. 25 000 hours
Light quality	homogeneous daylight, free of UV and IR	homogeneous daylight, free of UV and IR
Maintenance	maintenance free	maintenance-free
Power supply	universal from 100V to 240V, voltage-sensitive, integrated	universal from 100V to 240V, voltage-sensitive, integrated

Leica E Series – Features, specifications

Stereomicroscope	Leica ES2	Leica EZ4 10	Leica EZ4 16
Accessories			
Measurement graticule/ stage micrometer			
Other			
Dimensions and weights	3.82kg, 180 × 255 × 365	3.82kg, 180 × 255 × 365	3.82kg, 180 × 255 × 365
Ambient conditions, operation	+10°C to +40°C / rel. hum. to 35°C: 75% / atmospheric pressure 700 to 1060 hPa / storage: 20°C to 55°C		
Storage and transport	–20°C to + 52°C / rel. hum. 10 – 95% (non-condensing) / atmospheric pressure 500 to 1200 hPa		
Standards	CE Communauté Européenne / CSA Canadian Standards Association (USA, Canada)		

Stereomicroscope	Leica EZ4, open	Leica EZ4 HD 10×
Accessories		
Measurement graticule/ stage micrometer	for length measurements, for use with adjustable eyepieces	
Other		
Dimensions and weights	3.64kg, 280 × 255 × 365	4.17kg, 180 × 155 × 365
Ambient conditions, operation	+10°C to +40°C / rel. hum. to 35°C: 75% / atmospheric pressure 700 to 1060 hPa / storage: 20°C to 55°C	
Storage and transport	-20°C to + 52°C / rel. hum. 10 – 95% (non-condensing) / atmospheric pressure 500 to 1200 hPa	
Standards	CE Communauté Européenne / CSA Canadian Standards Association (USA, Canada)	
Digital camera		
Exposure time		2 milliseconds to 2 seconds
Live image		45 fps (1256 × 720 Px) – 20 fps (1920 × 1080 Px)
Full frame image acquisition		2048 × 1536 pixels, 3.1 megapixels
Movie clip		720 × 480 pixels (MP4)
Sensor size		6.55 mm × 4.92 mm
Pixel size		3.2 μm × 3.2 μm
Sensor grade		Micron 1/2" CMOS
Gain		1× to 20×
Color Depth		24-bit
Data format		JPEG / TIFF / BMP / MP4
Operating systems		Windows XP, Windows Vista, Windows 7, Macintosh OSX
Software available		LAS EZ software (PC), optional LAS modules Acquire (Macintosh)
Min. Computer configuration		Intel Pentium 4 or DuoCore, 2 GHz, 2 GB RAM, 24-bit graphics, 1248 × 1024, DVD
Min. Display Specification		1920 × 1080 resolution, HDMI connection, DVI connection possible with HDMI/DVI adapter cable (not provided)
Electric Interfaces		<ul style="list-style-type: none"> • Computer USB 2.0, mini-USB plug • High Definition connector Mini-HDMI, HD-ready, and full HD • LED with 2 colors Ready (green), image capture (red) • Integrated slot SD (Secure Digital) card • 1-8GB, WIFI, WORM supported • Black button for changing illumination modes (press 1 second), and switching from HD to PC mode (press for 5 seconds) • Red button for capture with SD card (press 1 second), camera reset (press 10 seconds), set new white balance (press 5 seconds)

Leica E Series – Optical data

ES2 (10 447 202)				EZ4 (10 447 197) and EZ4 HD with 10× eyepieces (10 450 500)			
Eyepieces	Position at magnification-changer	Magnification total	Object field ∅ in mm	Eyepieces	Position at magnification-changer	Magnification total	Object field ∅ in mm
10×/20	10	10×	20	10×/20	8	8×	25
	30	30×	6.7		10	10×	20
			12.5		12.5×	16	
			16		16×	12.5	
			20		20×	10	
			25		25×	8	
			30		30×	6.7	
			35		35×	5.7	

EZ4 with 16× eyepieces (10 447 198)				EZ4 without eyepieces (10 447 199) + eyepieces 10×/20			
Eyepieces	Position at magnification-changer	Magnification total	Object field ∅ in mm	Eyepieces	Position at magnification-changer	Magnification total	Object field ∅ in mm
16×/15	13	12.8×	18.8	10×/20	0.8	8×	25
	16	16×	15		1	10×	20
	20	20×	12		1.25	12.5×	16
	25	25.6×	9.4		1.6	16×	12.5
	32	32×	7.5		2	20×	10
	40	40×	6		2.5	25×	8
	50	48×	5		3	30×	6.7
	56	56×	4.3		3.5	35×	5.7

EZ4 without eyepieces (10 447 199) + eyepieces 16×/16				EZ4 without eyepieces (10 447 199) + eyepieces 20×/12			
Eyepieces	Position at magnification-changer	Magnification total	Object field ∅ in mm	Eyepieces	Position at magnification-changer	Magnification total	Object field ∅ in mm
16×/16	0.8	12.8×	20	20×/12	0.8	16×	15
	1	16×	16		1	20×	12
	1.25	20×	12.8		1.25	25×	9.6
	1.6	25.6×	10		1.6	32×	7.5
	2	32×	8		2	40×	6
	2.5	40×	6.4		2.5	50×	4.8
	3	48×	5.3		3	60×	4
	3.5	56×	4.6		3.5	70×	3.4



Leica Stereomicroscope ES2



Leica Stereomicroscope EZ4



Leica Stereomicroscope EZ4 HD

Leica E Series Assembly – diagram

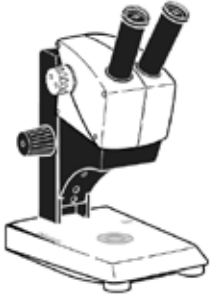

Leica ES2 (10×)
10 447 202

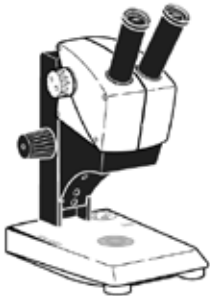

Leica EZ4 (10×)
10 447 197



Leica EZ4 (16×)
10 447 198



Leica EZ4
10 447 199

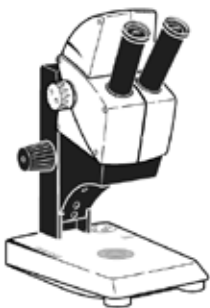

Leica EZ4 HD (10×)
10 450 500

Leica DC150 camera



Low eyepoint eyepieces:

Eyepieces, fixed:
10×/20 (10 447 281)
16×/16 (10 447 132)
20×/12 (10 447 134)

Eyepieces, adjustable:
10×/20 (10 447 282)
16×/16 (10 447 133)
20×/12 (10 447 135)

High eyepoint eyepieces:

Eyepieces, fixed:
10×/20B (10 447 278)
16×/15B (10 447 138)

Eyepieces, adjustable:
10×/20B (10 447 280)
16×/15B (10 447 139)

Leica E Series – Standard delivery

E Series stereomicroscopes

- 10 447 202 Leica ES2 with 10× eyepieces, 2 step stereomicroscope (3:1) 10× and 30× magnification, 60° eyetube angle, 100 mm working distance, high eyepoint eyepieces, integrated LED illumination for incident and transmitted light, power supply 100 – 240V
- 10 447 197 Leica EZ4 with 10× eyepieces, 4.4:1 zoom ratio, magnification from 8 – 35×, 60° eyetube angle, 100mm working distance, high eyepoint eyepieces, integrated LED illumination for incident and transmitted light, power supply 100 – 240V
- 10 447 198 Leica EZ4 with 16× eyepieces, 4.4:1 zoom ratio, magnification from 12.8 – 56×, 60° eyetube angle, 100mm working distance, high eyepoint eyepieces, integrated LED illumination for incident and transmitted light, power supply 100 – 240V
- 10 447 199 Leica EZ4 without eyepieces 4.4:1 zoom ratio, 60° eyetube angle, 100mm working distance, integrated LED illumination for incident and transmitted light, power supply 100 – 240V
- 10 450 500 Leica EZ4 HD with 10× eyepieces, 4.4:1 zoom ratio, magnification from 8 – 35×, 60° eyetube angle, 100mm working distance, high eyepoint eyepieces, integrated CMOS camera 3.0 Megapixel, USB2, HDMI, integrated LED illumination for incident and transmitted light, power supply 100 – 240V
- 13 613 726 Wireless Remote Camera Control for fine tuning the HD image and making additional camera settings when no computer is in use

Eyepieces for EZ4 with open tubes

- 10 447 281 Eyepiece 10×/20, fixed, E Series
- 10 447 282 Eyepiece 10×/20, adjustable, E Series
- 10 447 132 Eyepiece 16×/16, fixed, S and E Series
- 10 447 133 Eyepiece 16×/16, adjustable, S and E Series
- 10 447 134 Eyepiece 20×/12, fixed, S and E Series
- 10 447 135 Eyepiece 20×/12, adjustable, S and E Series
- 10 447 278 Eyepiece 10×/20B, for spectacle wearers
- 10 447 280 Eyepiece 10×/20B, adjustable, for spectacle wearers
- 10 447 138 Eyepiece 16×/15B, for spectacle wearers
- 10 447 139 Eyepiece 16×/15B, adjustable, for spectacle wearers

Accessories for measurements with adjustable eyepieces

- 10 446 447 Graticule 10mm / 0.1mm, S Series
- 10 446 448 Graticule 5mm / 0.1mm, S Series
- 10 446 449 Graticule 5mm / 0.05mm
- 10 446 450 Crosshair graticule
- 10 447 000 Graticule, 100 graduations / 0.002"
- 10 447 001 Graticule, 100 graduations / 0.001"
- 10 447 002 Graticule, 150 graduations / 0.0005"
- 10 310 345 Stage micrometer 50mm, 0.1 / 0.01mm graduation
- 10 447 037 Stage micrometer 1", 0.001" graduation
- 10 447 477 Soft carrying case
- 10 447 496 Leica ETB (Educational Tool Box): Educational CD-Rom, Cleaning-Set, Poster of an E-Series-Stereomicroscope

Leica ES2 dimensions

Measurements in mm

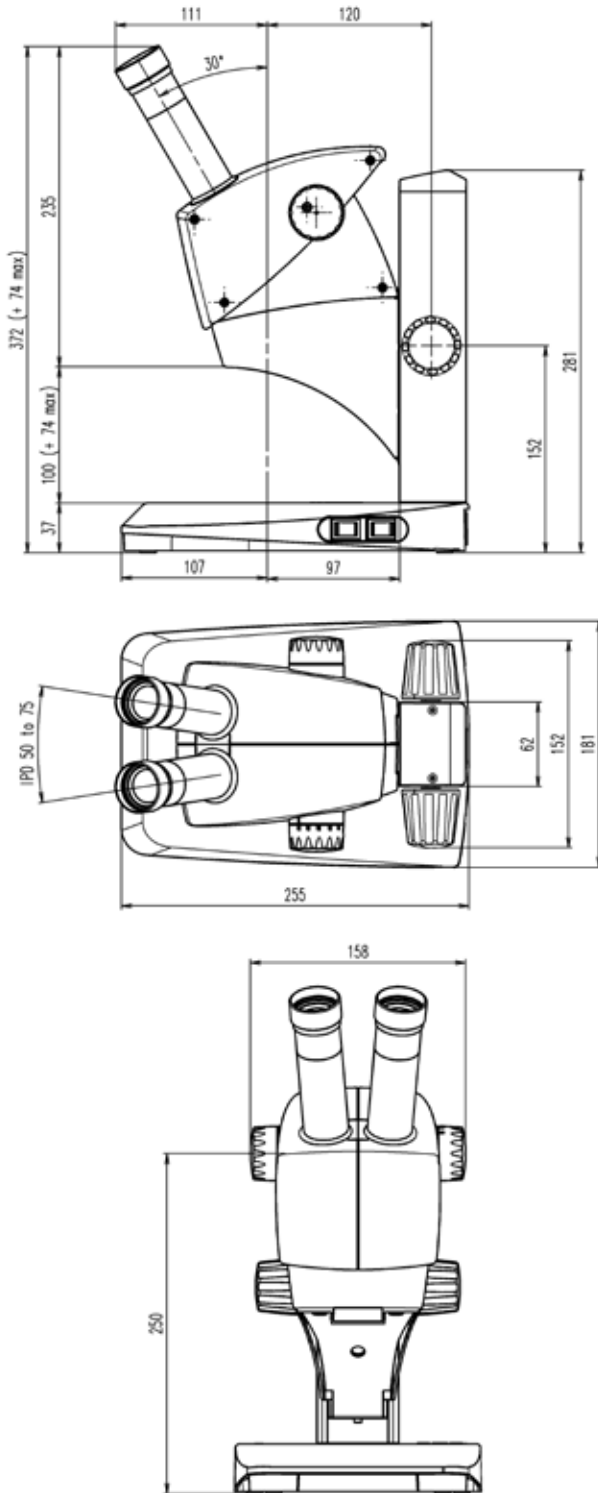

10 447 202 Leica ES2

Leica EZ4 dimensions

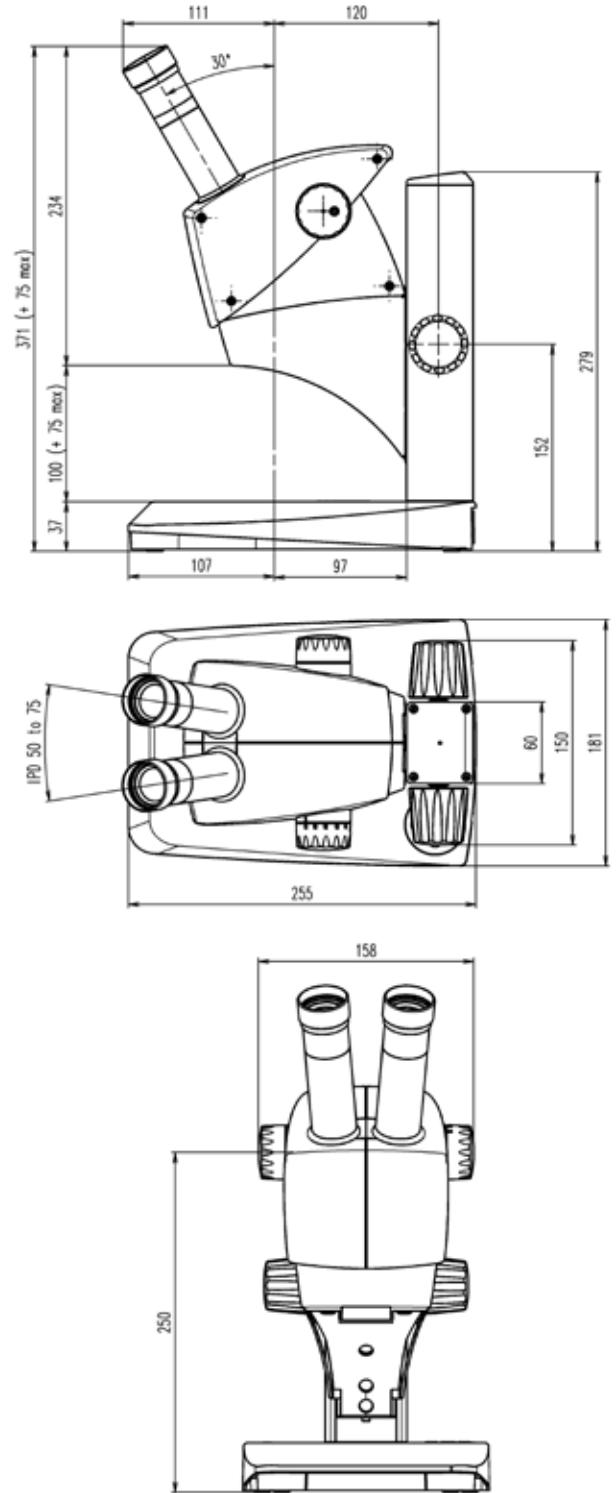

10 447 197 Leica EZ4 with 10× eyepieces
10 447 198 Leica EZ4 with 16× eyepieces

Leica EZ4 dimensions

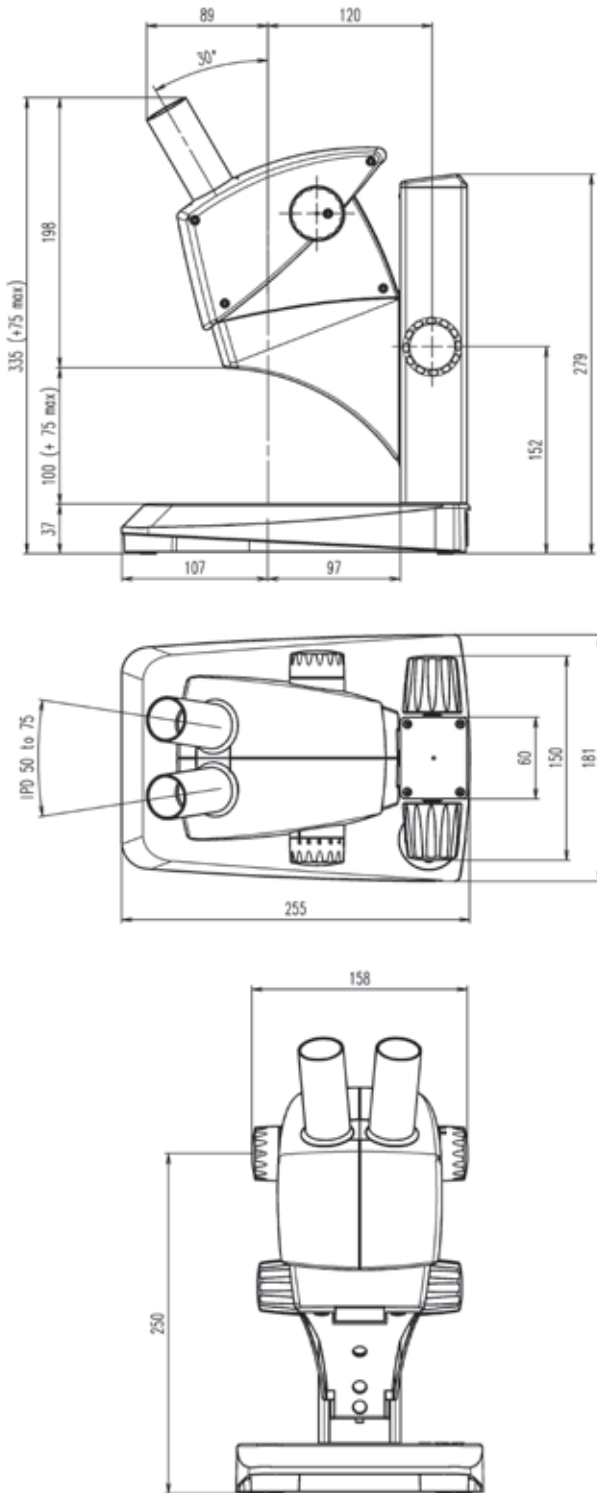

10 447 199 Leica EZ4 without eyepieces

Leica EZ4 HD dimensions

Measurements in mm

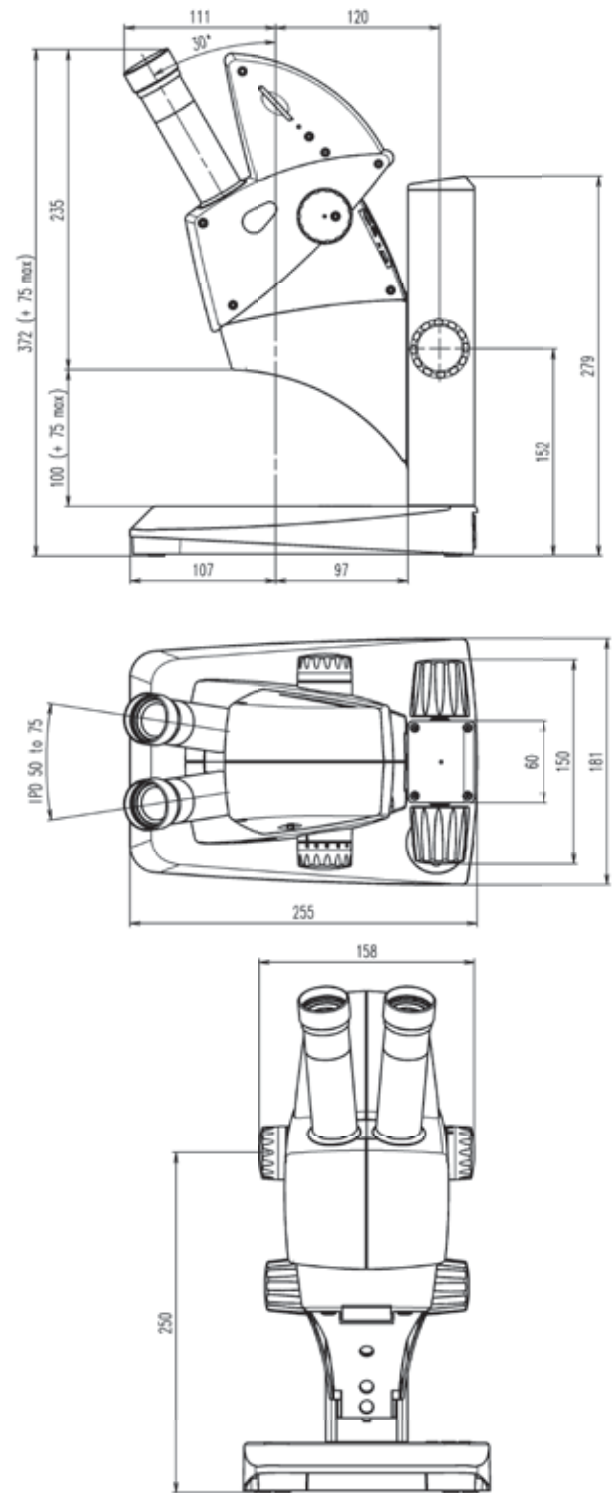

10 450 500 Leica EZ4 HD (with 10x eyepieces and integrated digital camera)

“With the user, for the user”

Leica Microsystems

Leica Microsystems operates globally in four divisions, where we rank with the market leaders.

• Life Science Division

The Leica Microsystems Life Science Division supports the imaging needs of the scientific community with advanced innovation and technical expertise for the visualization, measurement, and analysis of microstructures. Our strong focus on understanding scientific applications puts Leica Microsystems' customers at the leading edge of science.

• Industry Division

The Leica Microsystems Industry Division's focus is to support customers' pursuit of the highest quality end result. Leica Microsystems provide the best and most innovative imaging systems to see, measure, and analyze the microstructures in routine and research industrial applications, materials science, quality control, forensic science investigation, and educational applications.

• Biosystems Division

The Leica Microsystems Biosystems Division brings histopathology labs and researchers the highest-quality, most comprehensive product range. From patient to pathologist, the range includes the ideal product for each histology step and high-productivity workflow solutions for the entire lab. With complete histology systems featuring innovative automation and Novocastra™ reagents, Leica Microsystems creates better patient care through rapid turnaround, diagnostic confidence, and close customer collaboration.

• Medical Division

The Leica Microsystems Medical Division's focus is to partner with and support surgeons and their care of patients with the highest-quality, most innovative surgical microscope technology today and into the future.

The statement by Ernst Leitz in 1907, “with the user, for the user,” describes the fruitful collaboration with end users and driving force of innovation at Leica Microsystems. We have developed five brand values to live up to this tradition: Pioneering, High-end Quality, Team Spirit, Dedication to Science, and Continuous Improvement. For us, living up to these values means: **Living up to Life.**

Active worldwide

Australia:	North Ryde	Tel. +61 2 8870 3500	Fax +61 2 9878 1055
Austria:	Vienna	Tel. +43 1 486 80 50 0	Fax +43 1 486 80 50 30
Belgium:	Groot Bijgaarden	Tel. +32 2 790 98 50	Fax +32 2 790 98 68
Canada:	Richmond Hill/Ontario	Tel. +1 905 762 2000	Fax +1 905 762 8937
Denmark:	Ballerup	Tel. +45 4454 0101	Fax +45 4454 0111
France:	Nanterre Cedex	Tel. +33 811 000 664	Fax +33 1 56 05 23 23
Germany:	Wetzlar	Tel. +49 64 41 29 40 00	Fax +49 64 41 29 41 55
Italy:	Milan	Tel. +39 02 574 861	Fax +39 02 574 03392
Japan:	Tokyo	Tel. +81 3 5421 2800	Fax +81 3 5421 2896
Korea:	Seoul	Tel. +82 2 514 65 43	Fax +82 2 514 65 48
Netherlands:	Rijswijk	Tel. +31 70 4132 100	Fax +31 70 4132 109
People's Rep. of China:	Hong Kong	Tel. +852 2564 6699	Fax +852 2564 4163
Portugal:	Lisbon	Tel. +351 21 388 9112	Fax +351 21 385 4668
Singapore		Tel. +65 6779 7823	Fax +65 6773 0628
Spain:	Barcelona	Tel. +34 93 494 95 30	Fax +34 93 494 95 32
Sweden:	Kista	Tel. +46 8 625 45 45	Fax +46 8 625 45 10
Switzerland:	Heerbrugg	Tel. +41 71 726 34 34	Fax +41 71 726 34 44
United Kingdom:	Milton Keynes	Tel. +44 1908 246 246	Fax +44 1908 609 992
USA:	Bannockburn/Illinois	Tel. +1 847 405 0123	Fax +1 847 405 0164

and representatives in more than 100 countries

In accordance with the ISO 9001 certificate, Leica Microsystems (Switzerland) Ltd, Industry Division, has at its disposal a management system that meets the requirements of the international standard for quality management. In addition, production meets the requirements of the international standard ISO 14001 for environmental management.

www.leica-microsystems.com

ryf ag

Ryf AG
Bettlachstrasse 2
2540 Grenchen
tel 032 654 21 00
fax 032 654 21 09
www.ryfag.ch

MICROSYSTEMS