

Operating Manual
Axiolab 5



Upright Microscope for Routine and Entry-level Research

We make it visible.

Knowledge of this manual is essential for the operation of the instrument. Please familiarize yourself with the contents of this manual and pay special attention to instructions concerning safe operation of the instrument.

The specifications are subject to change; the manual is not covered by an update service.

© Unless expressly authorized, dissemination and duplication of this document as well as commercial exploitation and communication of its contents are not permitted. Persons in contravention of this copyright are liable to pay compensation for damages.

All rights reserved, including rights created by patent grant or registration of a utility model.

All names of companies and products mentioned in this manual may be trademarks or registered trademarks. Third party products are cited for information purposes only and this does not represent approval or recommendation of these products.

Carl Zeiss Microscopy GmbH assumes no liability for the performance or use of such products.

Published by Carl Zeiss Microscopy GmbH
Carl-Zeiss-Promenade 10
07745 Jena, Germany

microscopy@zeiss.com
www.zeiss.com/microscopy



Carl Zeiss Suzhou Co., Ltd.
Modern Industrial Square 3-B, No.333
XingPu Road SIP
215126 Suzhou, China

Order No.: 430037-7444-001

Date of issue: Version 6 – 15 May 2019

CONTENTS

	Page
1	INTRODUCTION 8
1.1	Notes on instrument safety 8
1.2	Warning labels on the microscopes..... 12
1.3	Notes on the warranty..... 14
2	DESCRIPTION OF THE INSTRUMENT 15
2.1	Intended use..... 15
2.2	Technical data..... 17
2.3	Interface diagram..... 20
2.4	Control and functional elements on the microscope..... 21
2.4.1	Stand models..... 21
2.4.2	Axiolab 5 stand, Bio-TL..... 22
2.4.3	Axiolab 5 stand, Bio-TL/FL..... 24
2.4.4	Axiolab 5 stand, Pol-TL 26
2.4.5	Axiolab 5 stand, Pol-TL/conoscopy 28
2.4.6	Axiolab 5 stand, Pol-TL/RL..... 30
2.4.7	Axiolab 5 stand, Mat-TL/RL..... 32
2.4.8	Functions of stands keys and display elements..... 34
2.5	Control and functional elements on microscope components..... 35
2.5.1	Binocular tubes/photo tubes 35
2.5.2	Microscope stages..... 38
2.5.3	Filter mount on luminous-field diaphragm operating ring for filter 32x4 mm 40
2.5.4	Condensers..... 40
2.5.5	Filter slider for reflected light stand 41
2.5.6	Reflector turret with 4 positions..... 41
2.5.7	Low-power system for objectives 2.5x/4x 41
2.5.8	Polarizer..... 42
2.5.9	Nosepiece with objectives..... 42
2.5.10	Microscope operating modes..... 43
2.5.11	Axiocam 202 mono/208 color controls and connectors 49
2.5.12	OSD functionality with Axiocam 202 mono/208 color..... 50
3	START-UP 51
3.1	Mounting standard components 51
3.1.1	Unpacking and setting up microscope stand 51
3.1.2	Attaching the binocular tube/photo tube 53
3.1.3	Inserting eyepieces or auxiliary microscope or pinhole diaphragm 54
3.1.4	Screwing in objectives 55
3.1.5	Inserting and removing P&C reflector modules in/from the reflector turret 56
3.1.6	Mounting a mechanical stage..... 57
3.1.7	Mounting the Pol rotary stage 59

3.1.8	Mounting the condenser.....	62
3.1.9	Mounting the darkfield condenser.....	63
3.1.10	Mounting or replacing the 35 W halogen lamp or the 10 W LED illuminator for transmitted light	64
3.1.11	Mounting or replacing the 35 W halogen lamp or the 10 W LED illuminator for reflected light	67
3.1.12	Installing or replacing the LED modules for reflected light fluorescence.....	70
3.1.13	Mounting the Axiocam 202 mono or Axiocam 208 color	72
3.2	Mounting optional components	73
3.2.1	Mounting the light intensive co-observer unit	73
3.2.2	Mounting polarizer D or filter holder	73
3.2.3	Mounting and centering the low-power system for the objectives 2.5x/4x	74
3.2.4	Inserting the modulator disk in the condenser 0.9 BF Pol.....	75
3.3	Connecting to the power supply.....	75
3.4	Switching the microscope on/off.....	76
3.5	Using the Light Manager function.....	77
3.6	Default factory settings of the microscope	78
4	OPERATION	79
4.1	Default setting of the microscope.....	79
4.1.1	Setting the inter-pupillary distance on the binocular tube	79
4.1.2	Setting the viewing height	79
4.1.3	Adjusting for ametropia (user's visual impairment) when using eyepiece reticles	80
4.2	Illumination and contrast methods in transmitted light.....	81
4.2.1	Configuring transmitted light brightfield microscopy using the KÖHLER method.....	81
4.2.2	Configuring transmitted light darkfield microscopy using the KÖHLER method	84
4.2.3	Configuring transmitted light phase contrast microscopy	87
4.2.4	Configuring transmitted light polarization microscopy.....	89
4.2.5	Configuring transmitted light polarization with the conoscopy stand.....	98
4.2.6	Configuring transmitted light polarization for conosopic observation – determining the optical character of crystals	109
4.3	Illumination and contrast methods in reflected light	112
4.3.1	Configuring reflected light brightfield microscopy using the KÖHLER method.....	112
4.3.2	Configuring reflected light darkfield microscopy	114
4.3.3	Configuring reflected light polarization – Proof of bireflectance and reflexion pleochroism.....	115
4.3.4	Setting reflected light fluorescence.....	116
5	CARE, FUSE REPLACEMENT AND SERVICE.....	119
5.1	Instrument care	119
5.2	Instrument maintenance	120
5.2.1	Checking the instrument.....	120
5.2.2	Replacing the fuses in the stand	120
5.3	Troubleshooting.....	121

5.3.1	Microscope	121
5.3.2	Axiocam 202/208.....	124
5.4	Maintenance and repair.....	126
5.5	Firmware update.....	126
6	APPENDIX	127
6.1	List of abbreviations	127
6.2	Index	129
6.3	Industrial property rights.....	132
6.4	System overview.....	132

LIST OF ILLUSTRATIONS

Fig. 1-1	Warning labels on the Axiolab 5 stand for transmitted light and reflected light.....	12
Fig. 1-2	Warning labels on the Axiolab 5 stand for transmitted light	13
Fig. 2-1	Interface diagram (Example: Axiolab 5 Mat-TL/RL stand)	20
Fig. 2-2	Axiolab 5 stand, Bio-TL	23
Fig. 2-3	Axiolab 5 stand, Bio-TL/FL	25
Fig. 2-4	Axiolab 5 stand, Pol-TL	27
Fig. 2-5	Axiolab 5 stand, Pol-TL/Conoscopy.....	29
Fig. 2-6	Axiolab 5 stand, Pol-TL/RL.....	31
Fig. 2-7	Axiolab 5 stand, Mat-TL/RL	33
Fig. 2-8	Binocular photo tube 30°/23 with fixed graduation 50:50.....	35
Fig. 2-9	Binocular photo tube 20°/23 with toggle graduation 100:0/0:100	35
Fig. 2-10	Binocular photo tube 30°/23 with toggle graduation 100:0/0:100	36
Fig. 2-11	Binocular ergo photo tube 20°/23 with vertical adjustment.....	37
Fig. 2-12	Mechanical stage 75x50 R with specimen holder	38
Fig. 2-13	Mechanical stage 75x50 R with specimen holder	38
Fig. 2-14	Mechanical stage for reflected light 75x30 R with specimen-holding plate.....	39
Fig. 2-15	Pol rotary stage	39
Fig. 2-16	Filter mount on luminous-field diaphragm operating ring for filter d=32x4 mm	40
Fig. 2-17	Condenser 0.9/1.25 BF, DF, Ph1, Ph2, Ph3 with modulator disk	40
Fig. 2-18	Condenser 0.9/1.25 BF	40
Fig. 2-19	4-position reflector turret.....	41
Fig. 2-20	Low-power system	41
Fig. 2-21	Polarizers.....	42
Fig. 2-22	Nosepiece of the transmitted/ reflected light polarization stand with mount for compensators.....	42
Fig. 2-23	Camera connection panel (rear side)	49
Fig. 2-24	Camera operator panel (right side)	49

Fig. 2-25	OSD menu, Home	50
Fig. 3-1	Setting up the microscope	51
Fig. 3-2	Placing tools in the storage compartment	52
Fig. 3-3	Attaching the binocular tube	53
Fig. 3-4	Inserting eyepieces	54
Fig. 3-5	Inserting the eyepiece reticle.....	54
Fig. 3-6	Screwing in objectives	55
Fig. 3-7	Replacing the reflector module	56
Fig. 3-8	Installing a mechanical stage	57
Fig. 3-9	Friction adjustment	58
Fig. 3-10	Replacing the snap-in Pol rotary stage, detachable Pol specimen guide and stage clips	59
Fig. 3-11	Centering the Pol rotary stage	60
Fig. 3-12	Centering objectives.....	61
Fig. 3-13	Attaching the condenser	62
Fig. 3-14	Mounting the darkfield condenser	63
Fig. 3-15	Removing the cover.....	64
Fig. 3-16	Changing the halogen lamp	64
Fig. 3-17	Removing the LED illuminator.....	65
Fig. 3-18	Changing the LED illuminator in the adapter.....	65
Fig. 3-19	Inserting the LED illuminator.....	66
Fig. 3-20	Removing the cover.....	67
Fig. 3-21	Changing the halogen lamp	67
Fig. 3-22	Swinging the loops out	68
Fig. 3-23	Changing the LED illuminator	68
Fig. 3-24	Changing the LED illuminator in the adapter.....	69
Fig. 3-25	Removing the module holder.....	70
Fig. 3-26	Changing the LED modules	70
Fig. 3-27	Mounting the Axiocam 202 mono or Axiocam 208 color.....	72
Fig. 3-28	Mounting the polarizer D	73
Fig. 3-29	Mounting the low-power system	74
Fig. 3-30	Modulator disk in condenser 0.9 H Pol.....	75
Fig. 3-31	Power supply connector on the back of the stand	75
Fig. 3-32	Mains switch on left side of microscope.....	76
Fig. 3-33	Intensity/LM knob and illumination modes	76
Fig. 4-1	Setting the inter-pupillary distance on the binocular tube	79
Fig. 4-2	Setting the viewing height on the binocular tube	79
Fig. 4-3	Microscope settings in transmitted light brightfield microscopy.....	82
Fig. 4-4	Setting the height stop on the condenser carrier	83
Fig. 4-5	Centering the darkfield stop on condenser, achromatic-aplanatic 0.9 H D Ph DIC.....	84
Fig. 4-6	Centering the annular phase diaphragm (light-colored, in the condenser) and the phase ring (dark-colored, in the object).....	88
Fig. 4-7	Components for transmitted light polarization	90
Fig. 4-8	Determining the polarization direction n_{γ}' using a synthetic fiber as an example.....	91

Fig. 4-9	Schematic diagram of the color charts developed by Michel-Lévy	93
Fig. 4-10	Components for circular polarization contrast	96
Fig. 4-11	Axiolab 5 for transmitted light conoscopy.....	98
Fig. 4-12	Determining optical character	100
Fig. 4-13	Components for transmitted light polarization on the conoscopy stand.....	102
Fig. 4-14	Determining the polarization direction n_{γ}' using a synthetic fiber as an example	103
Fig. 4-15	Schematic diagram of the color charts according to Michel-Lévy	105
Fig. 4-16	Components for circular polarization contrast on conoscopy stand.....	108
Fig. 4-17	Axiolab 5 for transmitted light conoscopy.....	110
Fig. 4-18	Determining the optical character	111
Fig. 4-19	Microscope settings in reflected light brightfield microscopy	113
Fig. 4-20	Components for reflected light fluorescence	118
Fig. 5-1	Replacing the fuses in the stand.....	120

1 INTRODUCTION







1.1 Notes on instrument safety

The Axiolab 5 microscopes were engineered, manufactured and tested in accordance with the DIN EN 61010-1 (IEC 61010-1) and IEC 61010-2-101 safety standards for electrical measuring, control and laboratory equipment.

The microscopes fulfill the requirements as stated in Directive 98/79/EC on in vitro diagnostic medical devices (IVDD) and bear the **CE** marking.

The present manual contains information and safety warnings with which the operator must comply.

The following warning, instructional and informational symbols are used in this manual:

	CAUTION Warns the operator of a possible danger.
	CAUTION Warns the operator of hot surfaces.
	CAUTION Warns the operator of the emission of UV radiation.
	CAUTION Warns the operator of the emission of LED radiation.
	CAUTION Warns the operator to disconnect the instrument from the power supply before opening or doing any work on the instrument.
	ATTENTION This symbol indicates the risk of damage to the instrument or the system.
	NOTE This symbol indicates information or instructions which must be followed especially carefully.

Axiolab 5 microscopes and their original accessories may be used only for the microscopy procedures described in this manual.

Compliance with the following instructions is mandatory:

	CAUTION The microscope may only be plugged into an electrical outlet equipped with a safety contact. The safety feature must not be disabled by using an extension cord which does not have a protective ground conductor.
---	--







	CAUTION Whenever it becomes apparent that any of the safety mechanisms are out of order, the microscope must be switched off and secured against any inadvertent use. Please contact the ZEISS Service Department or the Carl Zeiss Microscopy Service before switching the microscope on again.
---	--





	CAUTION The microscopes are equipped with integrated power supply units, which adapt to line voltages ranging from 100 V to 240 V and frequencies ranging from 50 to 60 Hz. No voltage adjustment is required on the microscopes themselves.
--	--

	CAUTION Always disconnect the microscope from the power supply before you open it or change a fuse! Make sure that the fuses are suitable for the applied nominal current. Never use any makeshift fuses and do not short-circuit the fuse holders.
---	--

	CAUTION The microscopes do not have any special safety devices to protect users from acid or from potentially infectious, toxic, radioactive or other samples that may be hazardous to your health. Compliance with all statutory requirements, especially national accident prevention regulations, is required when handling such samples.
---	--

	CAUTION Only authorized personnel are permitted to operate the instruments. The personnel must have been instructed about and be aware of the risks involved in using the microscope. The Axiolab is a precision instrument whose functionality can easily be damaged or even destroyed when handled improperly.
---	--

	<p>CAUTION</p> <p>Operating the instrument in an area with a potentially explosive atmosphere is prohibited. It may be operated only on stable, non-flammable surfaces. Specimens must be disposed of appropriately in accordance with applicable statutory regulations and internal work instructions.</p>
	<p>CAUTION</p> <p>The immersion fluid Immersol 518 N[®] can cause skin irritations. Avoid any contact with skin, eyes and clothes. Read the safety data sheets on Immersol 518 N[®], Immersol 518 F[®] and Immersol W[®] carefully. If skin contact occurs, wash off immediately using lots of water and soap. If eye contact occurs, flush with water immediately for at least 5 minutes. Seek medical assistance if irritation continues.</p>
	<p>CAUTION</p> <p>Dispose of immersion fluid Immersol 518 N[®] appropriately: Do not allow it to contaminate surface water or enter drains or the sewage system.</p>
	<p>CAUTION</p> <p>Do not bring any flammable or easily combustible materials into the light beam.</p>
	<p>CAUTION</p> <p>This device belongs to LED Risk Group 2 as specified in IEC 62471 and emits LED radiation. Never look into the LED beam of the illuminating device – either with or without optical instruments. Failure to comply with this warning may result in eye injuries!</p>
	<p>ATTENTION</p> <p>The manufacturer assumes no liability for any use of the microscope, its assemblies or individual parts if these are used in a manner or for any purpose other than those described in this operating manual. This also applies to any maintenance or repair work not performed by authorized maintenance and repair personnel. Moreover, the warranty and any claims thereunder will be voided.</p>
	<p>ATTENTION</p> <p>Dirt and dust may affect the microscope's performance. Protect it by using a dust cover when it is not in use. Always make sure that the instrument is switched off before covering it up.</p>

	ATTENTION Always position equipment in a manner that permits easy disconnection from the power supply.
	ATTENTION Do not use a power supply cable with an inadequate rating.
	ATTENTION Closing or covering the ventilation slits may result in heat accumulation which could damage the instrument and even start a fire. Ensure that the ventilation slits are always kept open, uncovered and clear. Do not insert or drop anything into them or let anything fall into them.
	ATTENTION Do not dispose of defective microscopes in the household waste. Comply with the applicable statutory regulations for their disposal. Specimens must also be disposed of appropriately in accordance with applicable statutory regulations and internal work instructions.

1.2 Warning labels on the microscopes

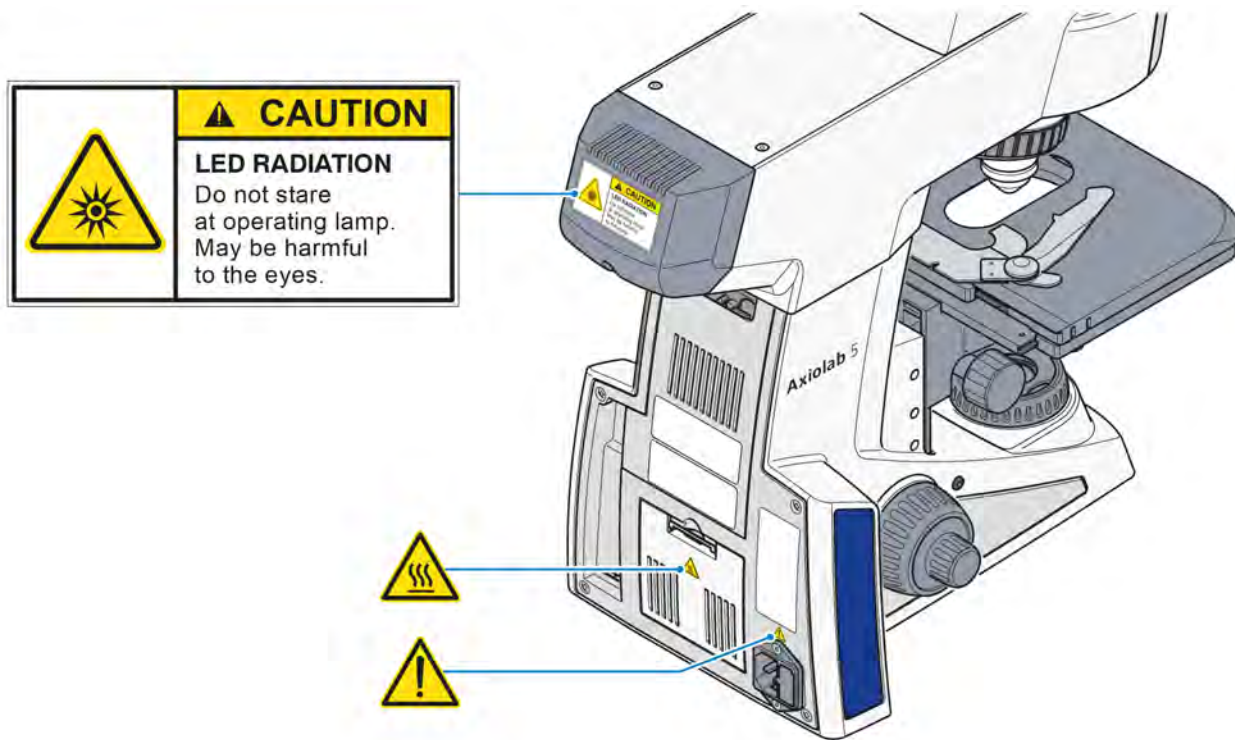

	<p>NOTE</p> <p>Warning label: Hot surface! Affixed to all stands with transmitted light halogen illumination.</p>
--	---

Fig. 1-1 Warning labels on the Axiolab 5 stand for transmitted light and reflected light

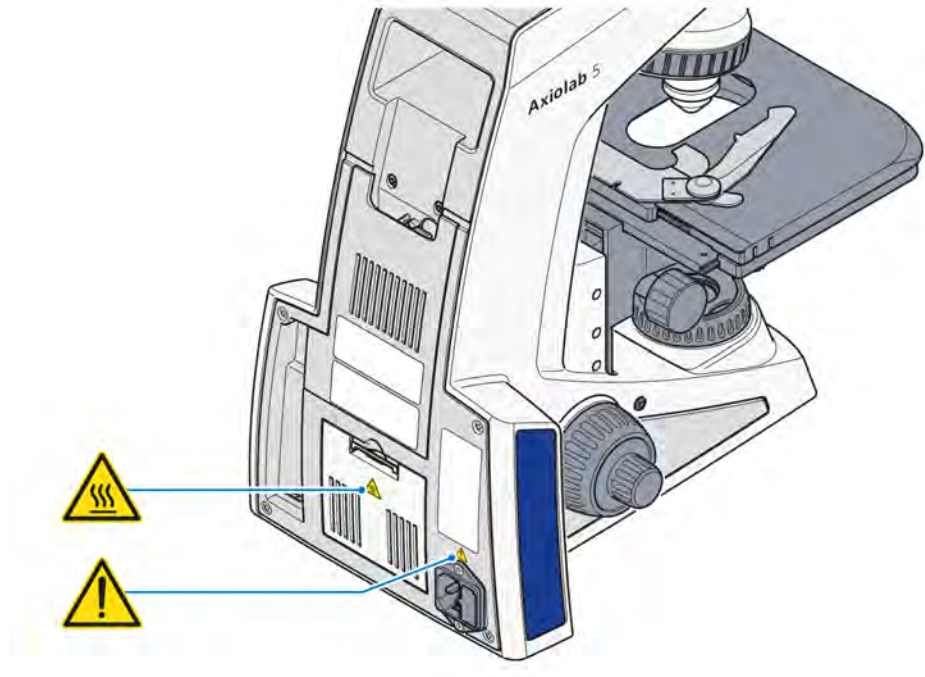

Fig. 1-2 Warning labels on the Axiolab 5 stand for transmitted light

1.3 Notes on the warranty

The manufacturer guarantees that the instrument is free of any material and workmanship defects upon delivery. If you become aware of any deficiencies, please contact us immediately and take all necessary precautions in order to avoid further damage. Upon notice of deficiencies, the manufacturer may choose to correct the deficiencies or to deliver a defect-free instrument at his discretion. Defects due to ordinary wear and tear (especially on wearing parts) and to improper handling are not covered by our warranty.

The manufacturer is not liable for damage to the instrument due to incorrect operation, negligence or any other manipulation of the instrument, in particular due to the removal or replacement of instrument parts or due to the use of accessories from other manufacturers. This will immediately void the warranty.

No maintenance or repair work, except for the instances mentioned in the manual, may be performed on the microscopes. Only ZEISS service personnel or personnel authorized especially by ZEISS may perform repair work on the microscopes. Should your instrument malfunction, please contact the ZEISS Microscopy Service Department (see page 126) or the ZEISS agency assigned to your country.

2 DESCRIPTION OF THE INSTRUMENT

2.1 Intended use

Axiolab 5 microscopes were designed as all-purpose microscopes for biological and medical applications as well as materials analyses.

Depending on the microscope stand selected, they may also be used as true transmitted or reflected light microscopes or as combined transmitted/reflected light fluorescence microscopes.

Typical biomedical applications of Axiolab 5 microscopes include:

- medical analysis in laboratories, clinics and medical practices
- science and research (colleges, universities) in the fields of medicine and biology
- industrial applications (pharmacology, food technology)
- analysis of human blood and tissue samples.

Axiolab 5 microscopes are typically used for materials analysis in the following areas, among others:

- metallographic laboratories
- automotive industry
- microsystems engineering
- geoscientific institutes
- mineral exploration industry

Depending on the instrument configuration, the following microscopy and contrasting techniques can be used:

Transmitted light

- Brightfield (BF)
- Darkfield (DF)
- Phase contrast (Ph)
- Polarization (Pol)
- Polarization (Conoscopy)
- Polarization (C-Pol)

Reflected light

- Brightfield (BF)
- Darkfield (DR)
- Polarization (Pol)
- Fluorescence (FL)
- Differential Interference Contrast (DIC)
- Circular differential interference contrast/total interference contrast (C-DIC/TIC)

The binocular photo tubes and suitable adapters permit one microscope camera, one reflex camera or one digital/video camera to be attached for documentation purposes.

The Axiolab 5 was specifically designed and developed for ergonomic use in lengthy routine applications, e.g. hematological, histological and cytological laboratory analyses.

Using a ZEISS Axiocam 202 mono or Axiocam 208 color camera, the microscope can be connected to an external HD monitor via an HDMI connection or to a PC/laptop via a USB connection to control camera functionality. Advanced analysis functions for recorded images are available if the ZEN software is installed on the PC. Furthermore, the camera functions can be controlled via WiFi connection from a tablet, PC or smartphone using the Labscope/Matscope app.

The ergonomic design elements of the microscopes include:

- vertically adjustable, swivel-type and swivel/vertically adjustable ergo tubes
- Latex free, skin-friendly surfaces on the binocular section of the tubes, control elements and stand
- stage drives whose height and friction can be adjusted
- optional use of fine focusing knobs in standard form or as a jog/shuttle knob
- special ergonomic arrangement of the four main control elements: focusing drive, stage drive, light manager control, and snap image button for comfortable operation

2.2 Technical data

Dimensions (length x width x height)

Axiolab 5 basic microscope stand
without tube (430037-9011-000) approx. 304 mm x 210 mm x 357.5 mm

The other stand models differ slightly in depth and significantly in height, depending on the tube used. An overview of viewing heights (eyepoint heights) of the various tubes can be found on page 19.

An estimate of the height of the stand with the respective tube can be obtained by adding:

- 10 mm to the viewing height in the lower position of the binocular section for tubes with a fixed viewing angle
- 10 mm to the viewing height of the upper limit for ergo tubes

Weight

Axiolab 5 microscope stand (depending on version and accessories) approx. 8 to 20 kg

Ambient conditions

Shipping (in packaging):

Permissible ambient temperature -40 to +70 °C
Permissible humidity (without condensation) max. 75% at 35 °C

Storage:

Permissible ambient temperature +10 to +40 °C
Permissible humidity (without condensation) max. 75% at 35 °C

Operation:

Permissible ambient temperature +10 to +40 °C
Permissible relative humidity (without condensation) max. 75% at 35 °C
Highest permitted altitude of use max. 2000 m
Air pressure 800 hPa to 1060 hPa
Degree of pollution 2

Operational specifications

Operational area Closed rooms
Protective class I
Protection type IP 20
Electrical safety in accordance with DIN EN 61010-1 (IEC 61010-1)
in compliance with CSA and UL regulations
Overvoltage category II
RFI suppression complies with EN 55011 Class B
Noise immunity complies with DIN EN 61326/A1
Mains voltage for the Axiolab 5 100 to 240 V
Mains frequency 50 to 60 Hz
Power consumption of the Axiolab 5 100 VA

Fuses in compliance with IEC 127

Axiolab 5 microscope stand 2 x T 3.15 A/H, 5x20 mm

Light sources

LED illumination with transmitted light/reflected light

Power consumption max. 10 W

Adjustment of light source continuous approx. 10 to 800 mA

Halogen lighting with transmitted light/reflected light

Power consumption max. 35 W

Adjustment of light source continuous, approx. 0.5 to 12 V

LED lighting with reflected light fluorescence with replaceable LED modules

Wavelengths optional 385, 470, 565, 625 nm

LED classification LED Risk Group 2 to IEC 62471

Axiolab 5

Stand with manual stage focusing

Coarse focusing approx. 4 mm/revolution

Fine focusing approx. 0.4 mm/revolution; 4 μ m scale interval

Lifting range depending on the stand, 15 mm/30 mm

Height stop factory pre-set

Condenser 0.9/1.25 BF with optional

modulator disk for brightfield, darkfield and
phase contrast 1, 2, 3

Manual objective change depending on the nosepiece, 5x BF Pol or 5x BF DF, M27, coded

Manual reflector module change for 4-position reflector turret, coded

Viewing height and tube angle

Order No.	Binocular tube	Viewing angle	Adjustment	Viewing height* in mm
425520-9000-000	Binocular tube 30°/23	30°	- None -	449 / 485
425520-9010-000	Binocular photo tube 30°/23 (50:50)	30°	- None -	449 / 485
425520-9020-000	Binocular photo tube 30°/23 (100:100) Bio	30°	- None -	449 / 485
425520-9030-000	Binocular photo tube 20°/23 (100:100)	20°	- None -	442 / 481
425520-9050-000	Binocular ergo tube 15°/23 (50/50), telescopic, height, upright image	15°	Height, telescopic	410 - 509
425520-9090-000	Binocular tube 20°/23	20°		442 / 481
425520-9100-000	Binocular photo tube 20°/23 Pol (100:100)	20°		442 / 481
425512-0000-000	Binocular ergo tube 20°/23 (100/100), reverse image, 44 mm height	20°	Height	457 - 574

* Viewing heights:

Tubes with fixed viewing angle without ergo function:

Binocular part, lower/upper e.g. 442 / 481 → 442 to 481 mm

Angle- and vertically adjustable ergo tubes:

Binocular part, lower/upper e.g. 457 / 574 → 457 to 574 mm

All specifications are for an inter-pupillary distance of 65 mm.

2.3 Interface diagram

The following figure shows a diagram of the interfaces of the microscope stand. The Axiolab 5 Mat-TL/RL stand is used here as an example.

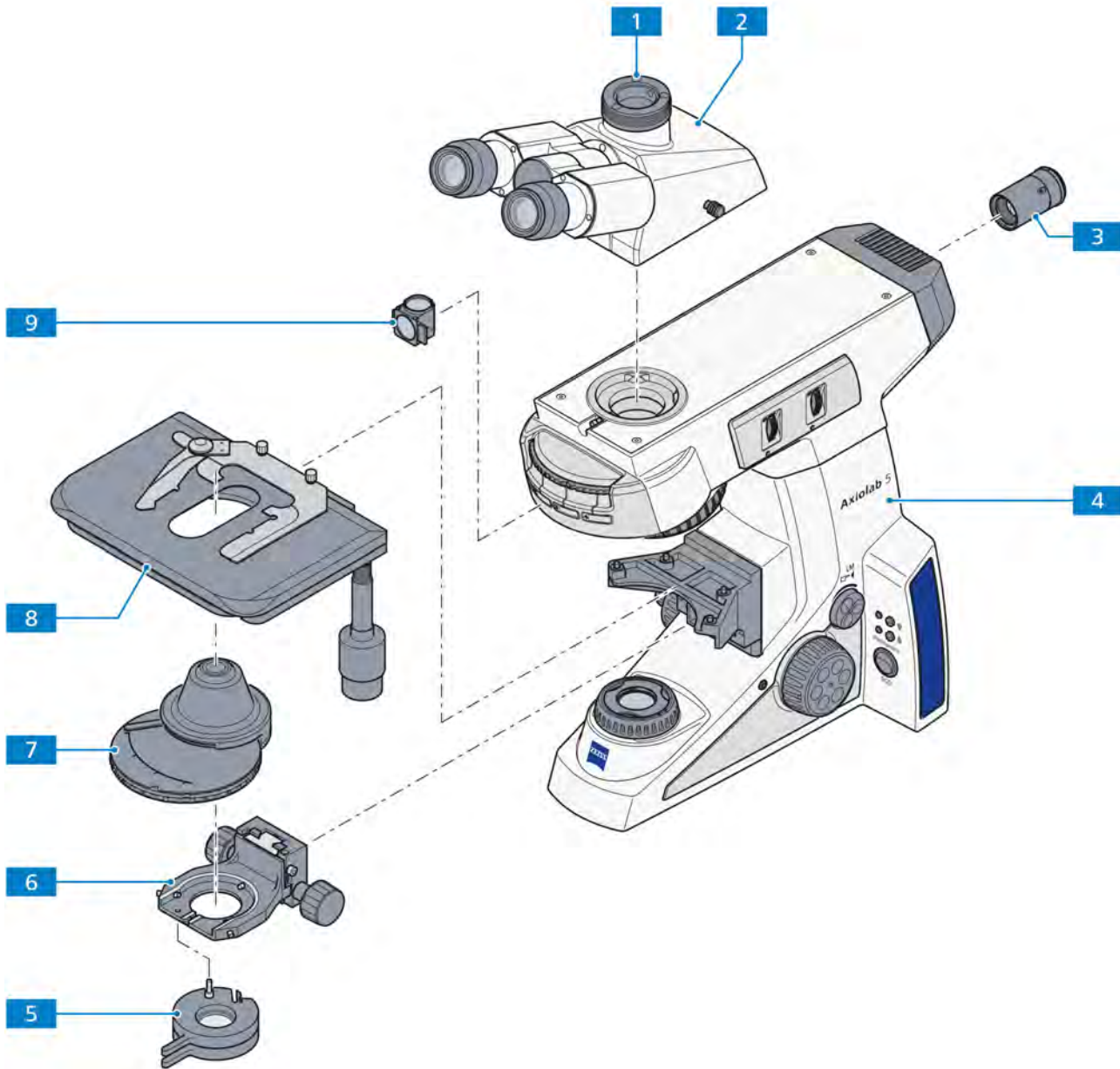

Fig. 2-1 Interface diagram (Example: Axiolab 5 Mat-TL/RL stand)

Key to Fig. 2-1:

- 1 Camera interface 60N on the phototube
- 2 Tube
- 3 LED illumination
- 4 Base stand
- 5 Polarizer or filter carrier
- 6 Condenser carrier
- 7 Condenser
- 8 Stage
- 9 Reflector module

2.4 Control and functional elements on the microscope

2.4.1 Stand models

Eight stand models are available in the delivery program:

1. Axiolab 5 stand, Bio-TL, XY stage with right handle (430037-9011-000)
2. Axiolab 5 stand, Bio-TL, XY stage with left handle (430037-9060-000)
3. Axiolab 5 stand, Bio-TL/FL, XY stage with right handle (430037-9021-000)
4. Axiolab 5 stand, Bio-TL/FL, XY stage with left handle (430037-9070-000)
5. Axiolab 5 stand Pol-TL, rotary stage (430037-9130-000)
6. Axiolab 5 stand, Pol-TL/conoscopy, rotary stage (430037-9042-000)
7. Axiolab 5 stand, Pol-TL/RL, rotary stage (430037-9032-000)
8. Axiolab 5 stand, Mat-TL/RL, XY stage with right handle (430037-9052-000)

2.4.2 Axiolab 5 stand, Bio-TL

Transmitted light stand for bioscience (430037-9011-000) equipped with the following main components:

1. LED 10W-TL illuminator, optional with halogen reflector lamp 12 V 35 W
2. Nosepiece with 5 positions BF, coded
3. Mechanical stage, 75x50, R/L
4. Binocular photo tube, 30x/23 (50:50), reversed image
5. Eyepiece E-PL 10x/22, GW, focusable
6. Condenser 0.9/1.25H

Legend of Fig. 2-2:

- 1 Eyepieces
- 2 Binocular section of tube
- 3 Binocular tube/photo tube
- 4 Carrying handle
- 5 Tool kit storage/cable holder
- 6 Transmitted light illuminator in stand base
- 7 Basic stand
- 8 Intensity/LM knob for light intensity and Light Manager function (LM)
- 9 Indicator light
- 10 Permanent/ECO mode switch
- 11 Focusing drive – fine adjustment (right side, finger wheel)
- 12 Focusing drive – coarse adjustment (right side)
- 13 Coaxial knurled knob for mechanical stage adjustment in the Y direction
- 14 Coaxial knurled knob for mechanical stage adjustment in the X direction
- 15 Snap button (right/left side)
- 16 Centering screw for condenser (right/left side)
- 17 Luminous-field diaphragm
- 18 Condenser with aperture diaphragm and modulator disk
- 19 Condenser carrier
- 20 Knurled knob for vertical adjustment of condenser (right/left side)
- 21 Stage carrier for mechanical stages
- 22 Focusing drive – coarse adjustment (left side)
- 23 Focusing drive – fine adjustment (left side)
- 24 On/off switch
- 25 Mechanical stage, 75x50 R, with specimen holder
- 26 Nosepiece with 5 positions BF, coded
- 27 Slot for 6x20mm slider

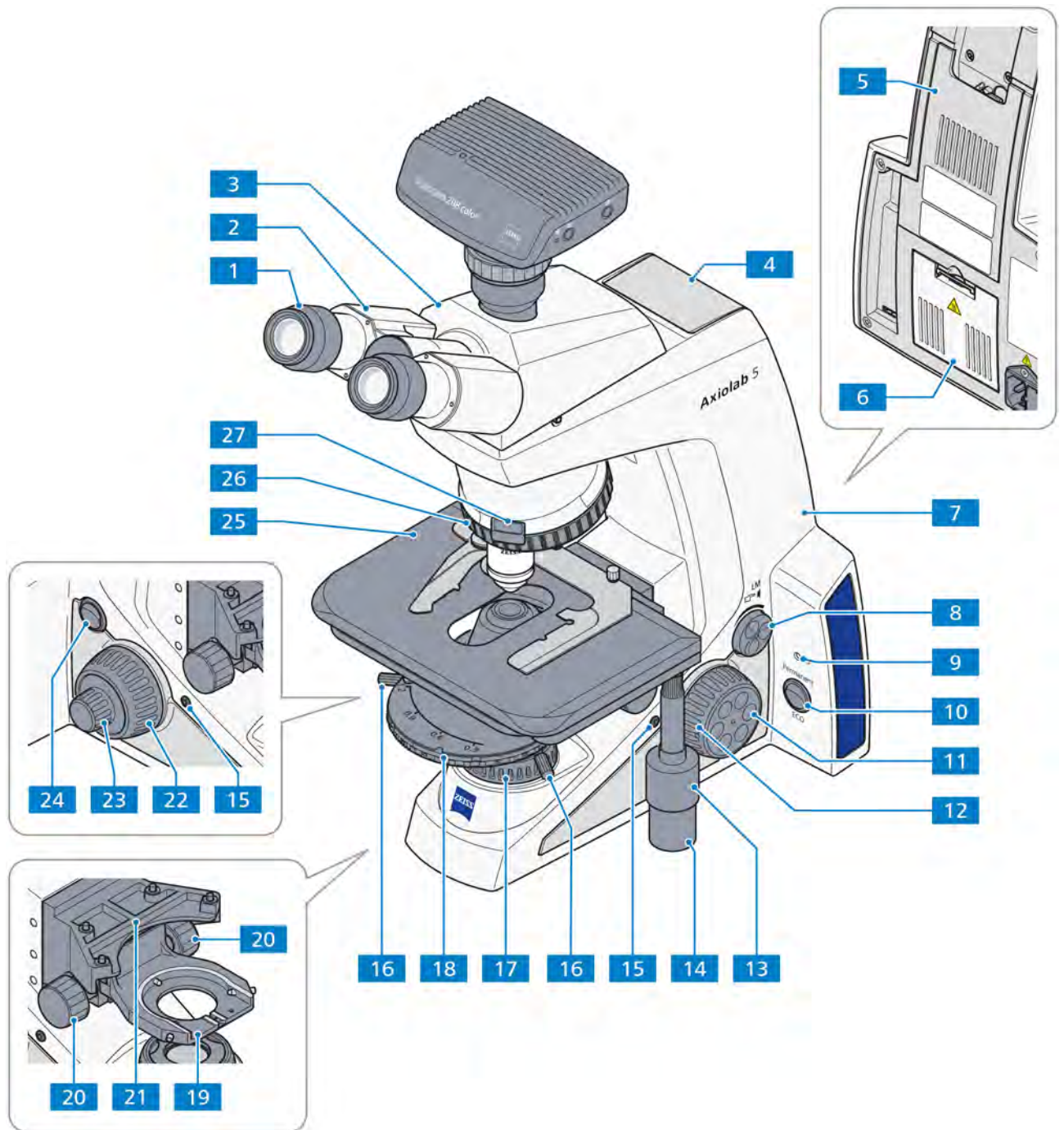

Fig. 2-2 Axiolab 5 stand, Bio-TL

2.4.3 Axiolab 5 stand, Bio-TL/FL

Transmitted light and reflected light fluorescence stand for bioscience (430037-9021-000) equipped with the following main components:

1. LED 10W-TL illumination, optional with halogen reflector lamp 12 V 35 W
2. FL-LED reflected light illumination with 3-position mount for LED
3. Nosepiece with 5 positions BF, coded
4. Mechanical stage, 75x50 R/L
5. 4-position reflector turret for P&C modules, coded
6. Binocular photo tube, 30x/23 (100:0/0:100), reversed image
7. Eyepiece E-PL 10x/22, GW, focusable
8. Condenser 0.9/1.25 BF

Legend of Fig. 2-3:

- 1 Eyepieces
- 2 Binocular section of tube
- 3 Binocular comfortable ergo tube
- 4 LED selection knob for 3 positions (UV, B, G)
- 5 FL-LED reflected light illumination
- 6 Tool kit storage/cable holder
- 7 Transmitted light illumination in stand base
- 8 Basic stand
- 9 Intensity/LM knob for light intensity and Light Manager function (LM)
- 10 Reflected light (RL) button and indicator light for reflected light
- 11 Transmitted light (TL) button and indicator light for transmitted light
- 12 Permanent/ECO mode switch
- 13 Focusing drive – fine adjustment (right side, finger wheel)
- 14 Focusing drive – coarse adjustment (right side)
- 15 Coaxial knurled knob for mechanical stage adjustment in the Y direction
- 16 Coaxial knurled knob for mechanical stage adjustment in the X direction
- 17 Snap button (right/left side)
- 18 Nosepiece with 5 positions BF, FL-LED
- 19 Luminous-field diaphragm
- 20 Slot for 6x20mm slider
- 21 Condenser
- 22 Knurled knob for vertical adjustment of condenser (right/left side)
- 23 Centering screw for condenser (right/left side)
- 24 Condenser carrier
- 25 Stage carrier for mechanical stages
- 26 Focusing drive – coarse adjustment (left side)
- 27 Focusing drive – fine adjustment (left side)
- 28 On/off switch
- 29 Mechanical stage, 75x50 R, with specimen holder
- 30 4-position reflector turret

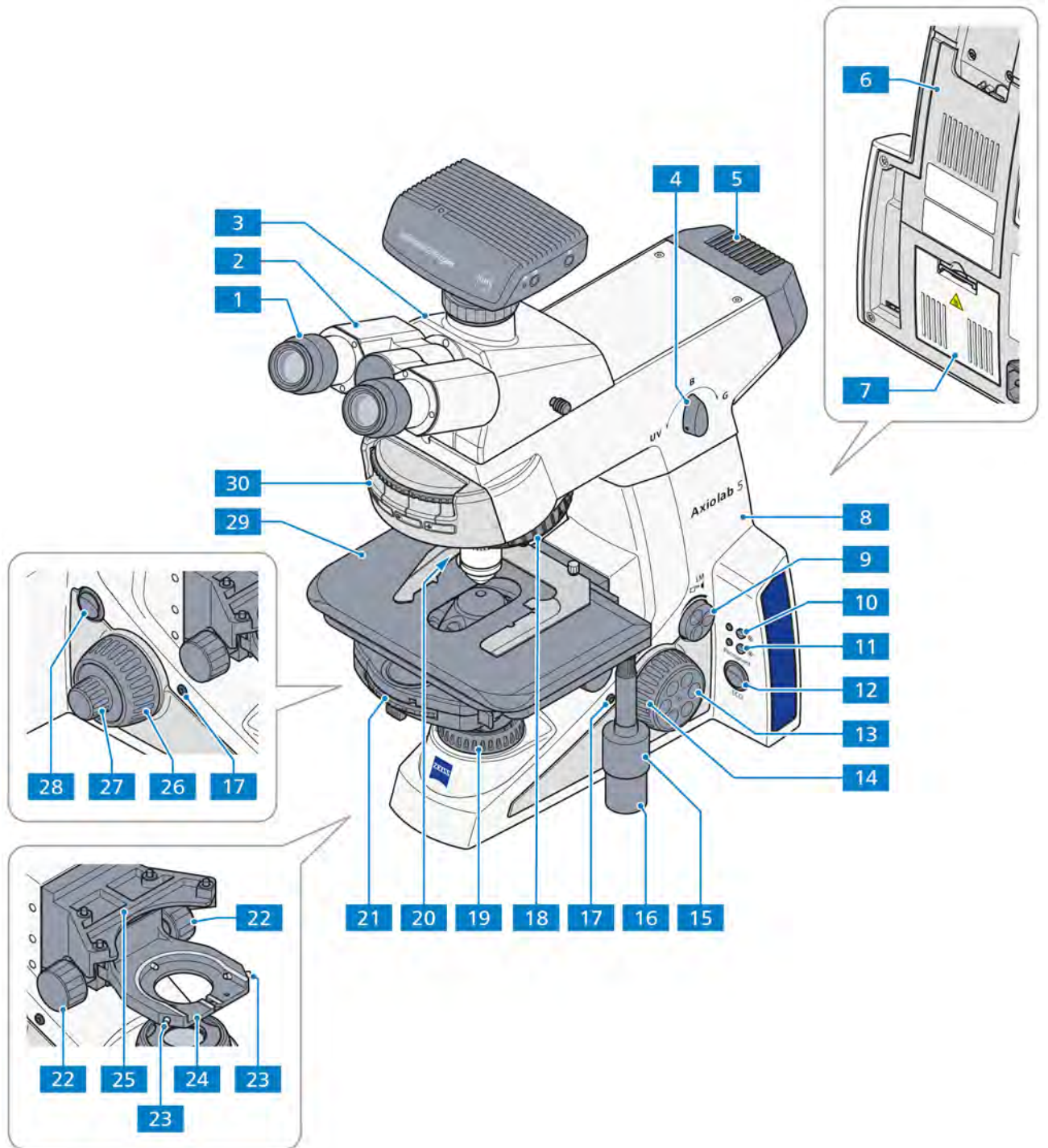

Fig. 2-3 Axiolab 5 stand, Bio-TL/FL

2.4.4 Axiolab 5 stand, Pol-TL

Transmitted light stand for polarization (430037-9130-000) with the following main components:

1. LED 10W-TL illumination, optional with halogen reflector lamp 12 V 35 W
2. Nosepiece with 5 positions BF Pol (with 4x centerable, 1x fixed), coded
3. Rotary stage Pol, 360° with clamping device click stop per 45°
4. Polarizer D, fixed, removable
5. Binocular photo tube 30x/23 (100:0/0:100), reversed image
6. Eyepiece E-PL 10x/22, GW, focusable, Pol
7. Condenser 0.9 BF Pol

Legend of Fig. 2-4:

- 1 Eyepieces
- 2 Binocular section of tube
- 3 Binocular tube/photo tube
- 4 Carrying handle
- 5 Tool kit storage/cable holder
- 6 Transmitted light illumination
- 7 Basic stand
- 8 Intensity/LM knob for light intensity and Light Manager function (LM)
- 9 Indicator light
- 10 Permanent/ECO mode switch
- 11 Focusing drive – fine adjustment (right side)
- 12 Focusing drive – coarse adjustment (right side)
- 13 Snap button (right/left side)
- 14 Knurled knob for vertical adjustment of condenser (right/left side)
- 15 Locking screw for rotary stage (arrests rotation)
- 16 Nosepiece with 5 positions BF Pol (with 4x centerable, 1x fixed)
- 17 Centering screw for condenser (right/left side)
- 18 Luminous-field diaphragm
- 19 Condenser with aperture diaphragm and modulator disk
- 20 Rotary stage lock in stage carrier
- 21 Polarizer D, fixed, removable
- 22 Condenser carrier
- 23 Stage carrier for rotary stages (also suitable for mechanical stages)
- 24 Focusing drive – coarse adjustment (left side)
- 25 Focusing drive – fine adjustment (left side)
- 26 On/off switch
- 27 Rotary stage, Pol 360° (click stop every 45°) with specimen guide
- 28 Slot for 6x20mm slider

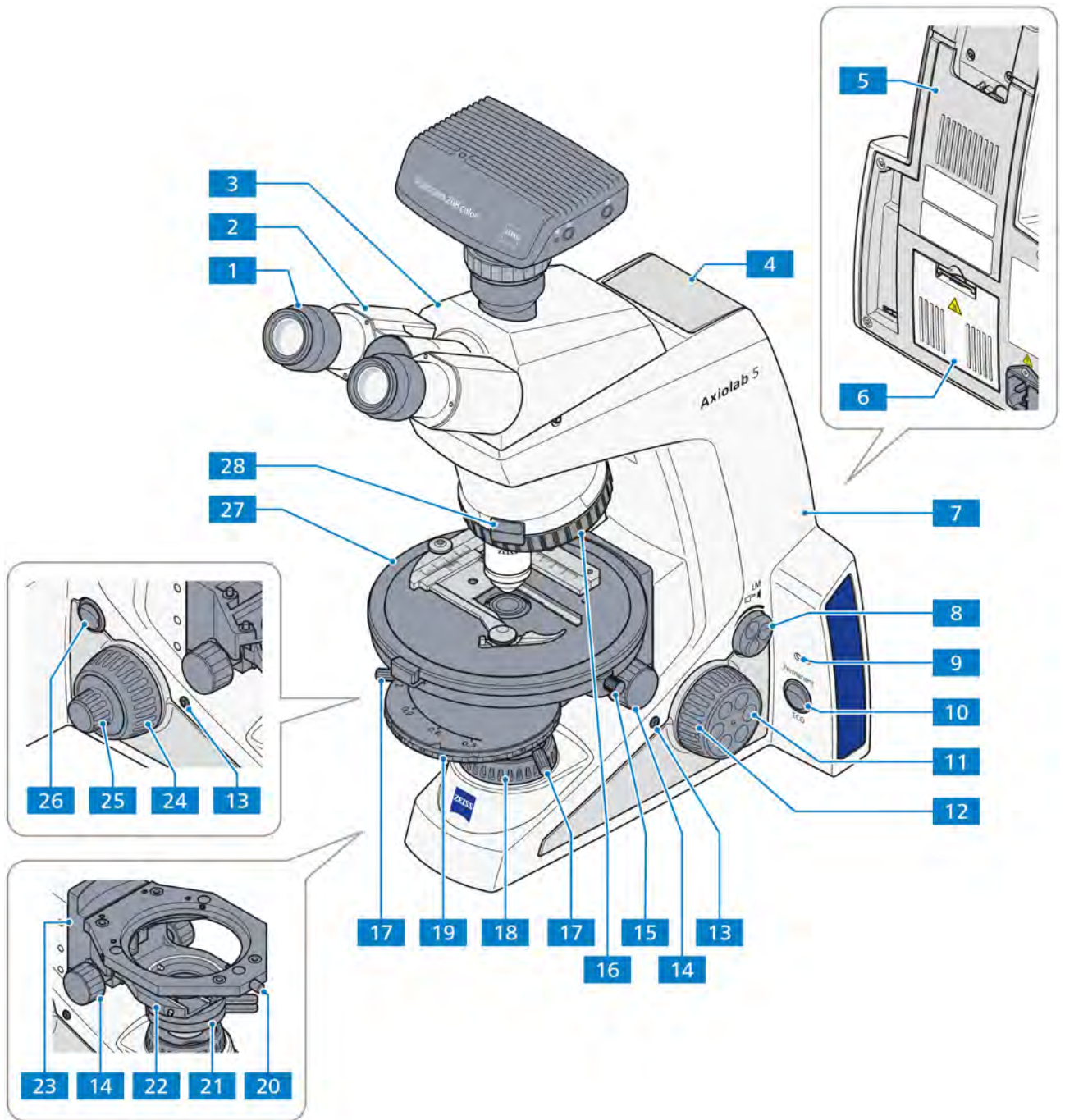

Fig. 2-4 Axiolab 5 stand, Pol-TL

2.4.5 Axiolab 5 stand, Pol-TL/conoscopy

Transmitted light stand for polarization/conoscopy (430037-9042-000) with the following main components:

1. LED 10W-TL illumination, optional with halogen reflector lamp 12 V 35 W
2. Nosepiece with 5 positions BF Pol (with 4x centerable, 1x fixed), coded
3. Rotary stage Pol, 360° with clamping device click stop per 45°
4. Polarizer D, fixed, removable
5. Binocular photo tube 30x/23 (100:0/0:100), reversed image
6. Eyepiece E-PL 10x/22 GW, focusable, Pol
7. Condenser 0.9 BF Pol

Legend of Fig. 2-5:

- 1 Eyepieces
- 2 Binocular section of tube
- 3 Binocular tube/photo tube
- 4 Carrying handle
- 5 Storage compartments for two 6x20mm sliders
- 6 Tool kit storage/cable holder
- 7 Transmitted light illumination
- 8 Basic stand
- 9 Rotary knob **BL**: Swiveling Bertrand lens in/out
- 10 Rotary knob **A**: Swiveling analyzer in/out
- 11 Intensity/LM knob for light intensity and Light Manager function (LM)
- 12 Indicator light
- 13 Permanent/ECO mode switch
- 14 Focusing drive – fine adjustment (right side)
- 15 Focusing drive – coarse adjustment (right side)
- 16 Snap button (right/left side)
- 17 Knurled knob for vertical adjustment of condenser (right/left side)
- 18 Locking screw for rotary stage (arrests rotation)
- 19 Nosepiece with 5 positions BF Pol (with 4x centerable, 1x fixed)
- 20 Centering screw for condenser (right/left side)
- 21 Luminous-field diaphragm
- 22 Slot for 6x20mm slider
- 23 Condenser with aperture diaphragm and modulator disk
- 24 Rotary stage lock in stage carrier
- 25 Polarizer D, fixed, removable
- 26 Condenser carrier
- 27 Stage carrier for rotary stages (also suitable for mechanical stages)
- 28 Focusing drive – coarse adjustment (left side)
- 29 Focusing drive – fine adjustment (left side)
- 30 On/off switch
- 31 Rotary stage, Pol 360° (click stop every 45°) with specimen guide
- 32 Setting wheel for polarization direction of analyzer
- 33 Setting wheel for focusing of Bertrand lens

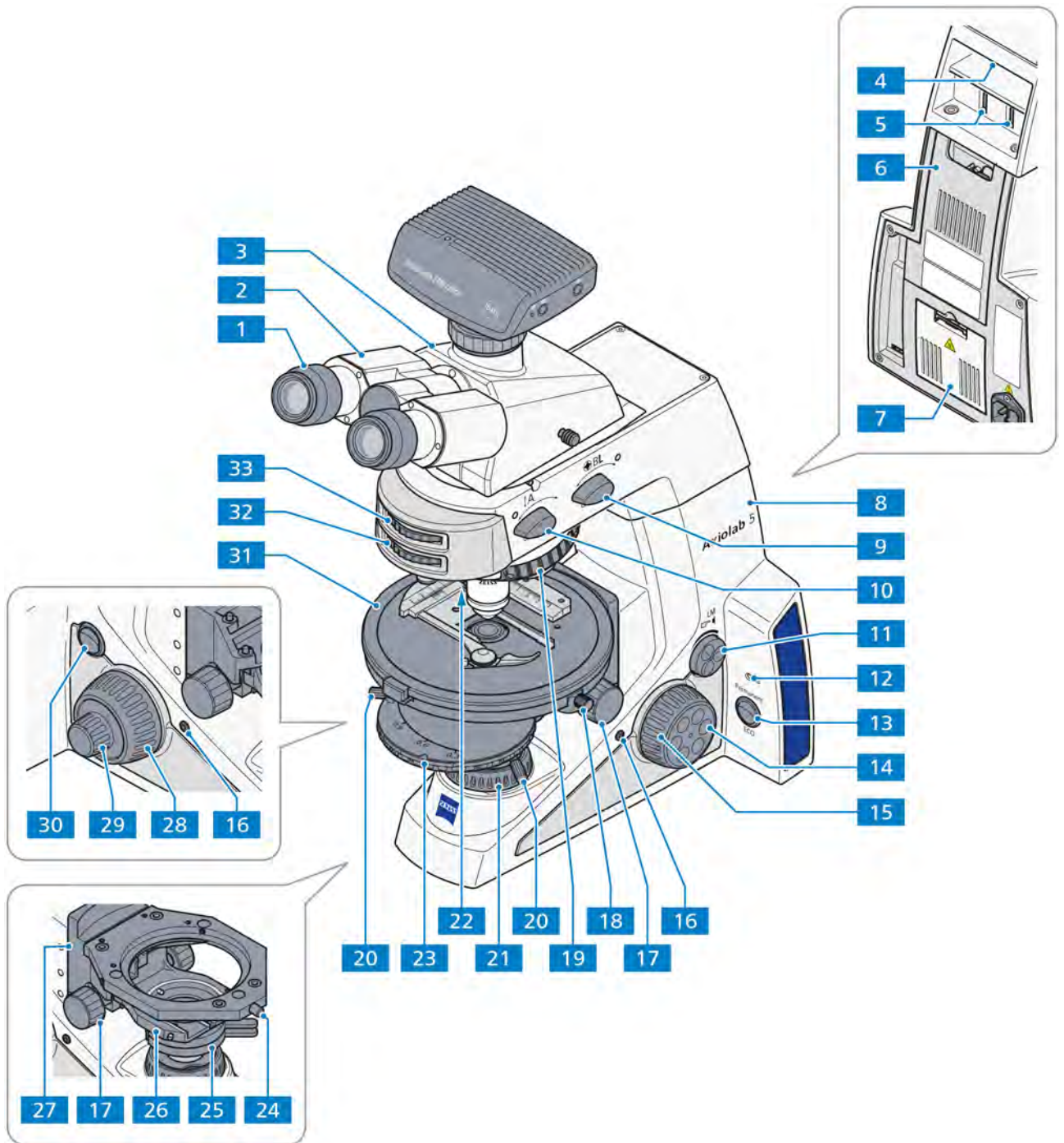

Fig. 2-5 Axiolab 5 stand, Pol-TL/Conoscopy

	ATTENTION
<p>The movements of rotary knobs A and BL (Fig. 2-5/9 and 10) and the respective setting wheels (Fig. 2-5/33 and 32) are coupled with each other. This means that only one control element should be operated at a time and the movement of the other should not be inhibited or blocked. Otherwise, mechanical damage may occur.</p>	

2.4.6 Axiolab 5 stand, Pol-TL/RL

Transmitted light and reflected light stand for polarization (430037-9032-000) with the following main components:

1. LED 10W-TL illumination, optional with halogen reflector lamp 12 V 35 W
2. LED 10W-RL illumination
3. Nosepiece with 5 positions BF DF Pol (with 4x centerable, 1x fixed), coded
4. Rotary stage Pol, 360° with clamping device click stop per 45°
5. Polarizer D, fixed, removable
6. Polarizer slider A, 6x30mm, 90° rotatable
7. 4-position reflector turret for P&C modules, coded
8. Binocular photo tube 30°/23 (50/50), reversed image
9. Eyepiece E-PL 10x/22 GW, focusable, Pol
10. Condenser 0.9 BF Pol

Legend of Fig. 2-6:

- 1 Eyepieces
- 2 Binocular section of tube
- 3 Binocular tube/photo tube
- 4 Slot for polarizer slider 6x30 mm, reflected light
- 5 Slot for filter slider, reflected light
- 6 Luminous-field diaphragm (centered)
- 7 Aperture diaphragm (centered)
- 8 Reflected light illumination
- 9 Tool kit storage flap/cable holder
- 10 Transmitted light illuminator in stand base
- 11 Basic stand
- 12 Intensity/LM knob for light intensity and Light Manager function (LM)
- 13 Reflected light (RL) button and indicator light for reflected light
- 14 Transmitted light (TL) button and indicator light for transmitted light
- 15 Permanent/ECO mode switch
- 16 Focusing drive – fine adjustment (right side, finger wheel)
- 17 Focusing drive – coarse adjustment (right side)
- 18 Snap button (right/left side)
- 19 Knurled knob for vertical adjustment of condenser (right/left side)
- 20 Locking screw for rotary table (arrests rotation)
- 21 Nosepiece, with 5 positions BF DF Pol (with 4x centerable, 1x fixed)
- 22 Centering screw for condenser (right/left side)
- 23 Luminous-field diaphragm
- 24 Slot for 6x20mm slider
- 25 Condenser with aperture diaphragm and modulator disk
- 26 Rotary stage lock in stage carrier
- 27 Polarizer D, fixed, removable
- 28 Condenser carrier
- 29 Stage carrier for rotary stages (also suitable for mechanical stages)
- 30 Focusing drive – coarse adjustment (left side)
- 31 Focusing drive – fine adjustment (left side)
- 32 On/off switch
- 33 Rotary stage, Pol 360° (click stop every 45°) with specimen guide
- 34 4-position reflector turret

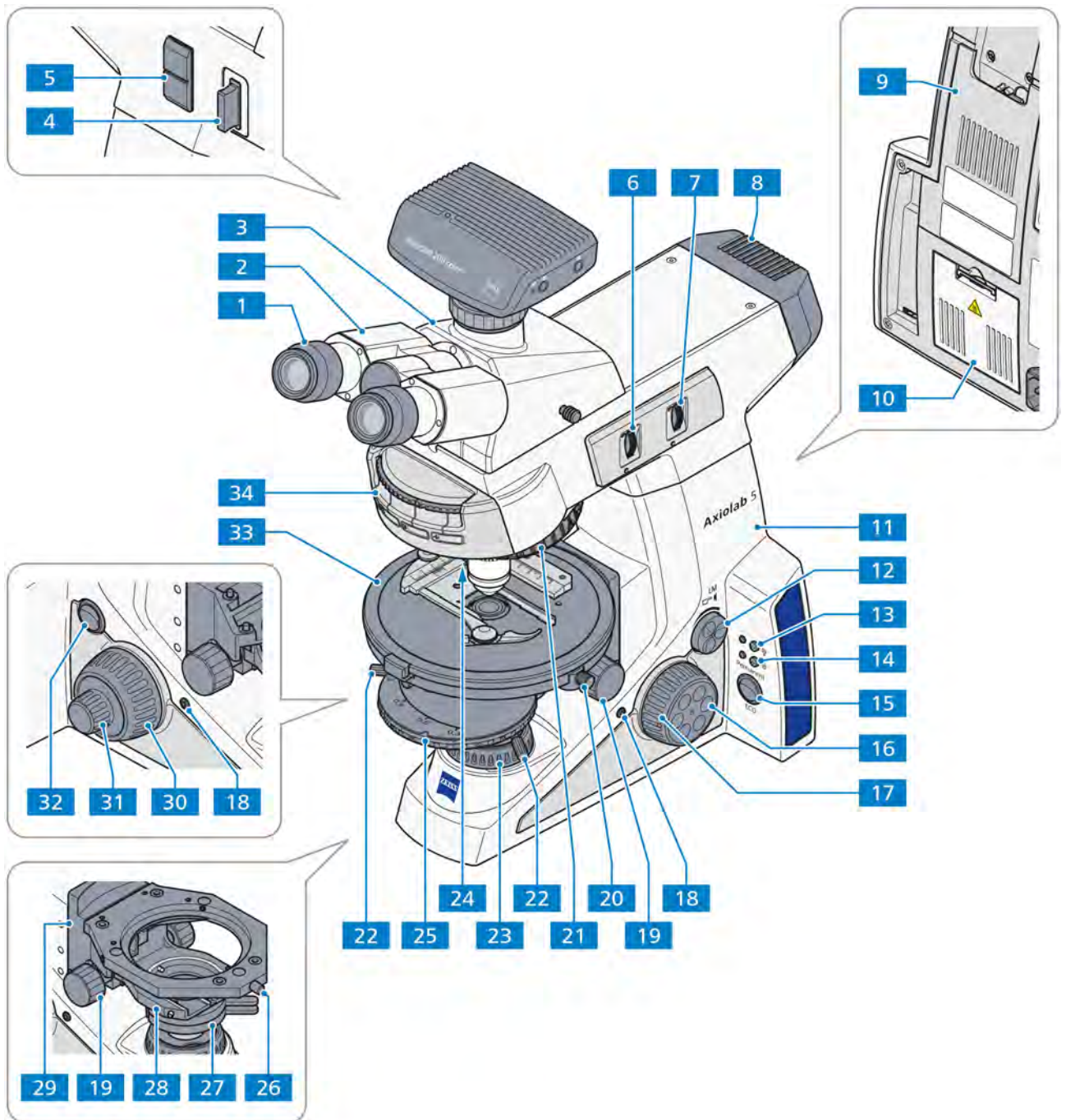

Fig. 2-6 Axiolab 5 stand, Pol-TL/RL

2.4.7 Axiolab 5 stand, Mat-TL/RL

Transmitted light and reflected light materials stand (430037-9052-000) with the following main components:

1. LED 10W-TL illumination, optional with halogen reflector lamp 12 V 35 W
2. LED 10W-RL illumination
3. Nosepiece with 5 positions BF DF, coded
4. Mechanical stage, 75x30 R
5. 4-position reflector turret for P&C modules, coded
6. Binocular photo tube 20°/23 (100:0/0:100), upright image with sliding prism
7. Eyepiece E-PL 10x/22 GW, focusable
8. Condenser 0.9/1.25 BF

Legend of Fig. 2-7:

- 1** Eyepieces
- 2** Binocular section of tube
- 3** Binocular tube/photo tube
- 4** Slot for polarizer slider 6x30 mm, reflected light
- 5** Slot for filter slider, reflected light
- 6** Luminous-field diaphragm (centered)
- 7** Aperture diaphragm (centered)
- 8** Reflected light illumination
- 9** Tool kit storage/cable holder
- 10** Transmitted light illuminator in stand base
- 11** Basic stand
- 12** Intensity/LM knob for light intensity and Light Manager function (LM)
- 13** Reflected light (RL) button with indicator light for reflected light
- 14** Transmitted light (TL) button with indicator light for transmitted light
- 15** Permanent/ECO mode switch
- 16** Focusing drive – fine adjustment (right side, finger wheel)
- 17** Focusing drive – coarse adjustment (right side)
- 18** Coaxial knurled knob for mechanical stage adjustment in Y direction
- 19** Coaxial knurled knob for mechanical stage adjustment in X direction
- 20** Snap button (right/left side)
- 21** Nosepiece, with 5 positions BF DF
- 22** Luminous-field diaphragm
- 23** Slot for 6x20mm slider
- 24** Condenser with aperture diaphragm
- 25** Knurled knob for vertical adjustment of condenser (right/left side)
- 26** Centering screw for condenser (right/left side)
- 27** Condenser carrier
- 28** Stage carrier
- 29** Focusing drive – coarse adjustment (left side)
- 30** Focusing drive – fine adjustment (left side)
- 31** On/off switch
- 32** Mechanical stage, 75x30 R, with specimen holder
- 33** 4-position reflector turret

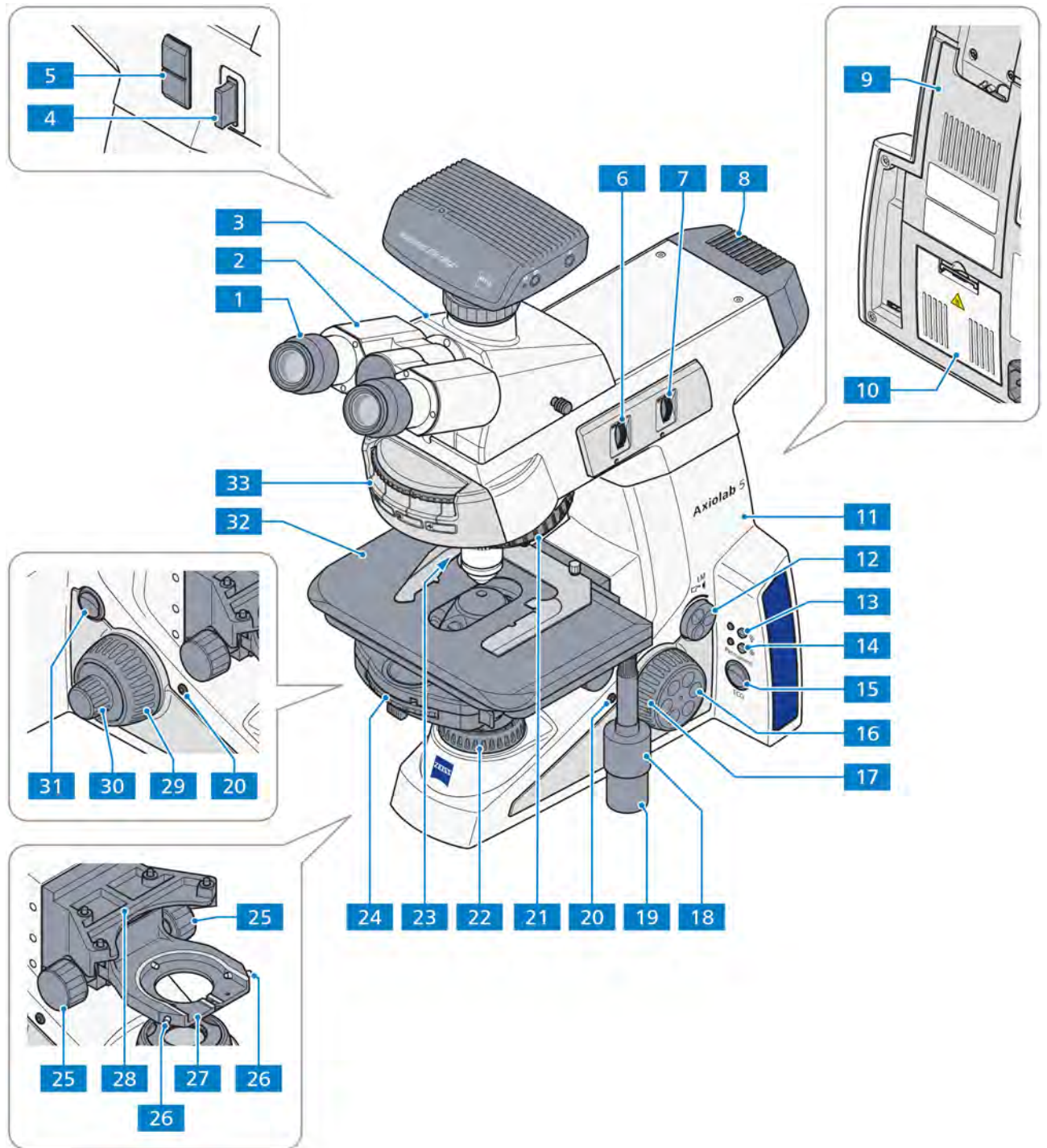

Fig. 2-7 Axiolab 5 stand, Mat-TL/RL

2.4.8 Functions of stands keys and display elements

For the location of the keys and display elements at your stand, refer to section 2.4.2 to 2.4.7.

Key	Action	Functionality/Description
On/off switch I/O (see Fig. 2-3/28)	I = on; O = off	Switches the microscope on/off
Permanent/ ECO switch (see Fig. 2-3/12)	Switch:	Switches between Permanent (continuous) mode and ECO mode of the microscope illumination: - Permanent mode active: illumination is continuously switched on. - ECO mode active: illumination switches off after 15 minutes without action. Note: Don't use ECO mode for experiments involving time-lapse or video recording.
Indicator light (see Fig. 2-3/10 and 11)	Blinking ***:	Indicates whether microscope is working in TL or RL mode.
RL/TL button (see Fig. 2-3/10 and 11)	Short press *:	Switches RL/TL light source alternately on/off. The respective indicator light is continuously illuminated.
Intensity/ LM knob (see Fig. 2-3/9)	Turn:	Controls the light intensity of the active light source.
	Long press **:	Light Manager function: Saves the light intensity; after saving is done, the LED switches off for 300 ms (darkness indicates action to user).
	Long press for 20 s:	Activates the factory default settings (enables/disables Light Manager functionality). The indicator light starts blinking in RED after 3 s until 20 s is reached. After 20 s, the indicator light turns to GREEN continuously.
Left Snap button or Right Snap button (see Fig. 2-3/17) (only if Axiocam 202 or 208 is attached)	Short press *:	Snaps an image; after snap is finished, the monitor display appears in BLACK for 50 ms.
	Long press **:	Starts video recording; another short press is required to stop recording. After recording is finished, the monitor display appears in BLACK for 300ms.
Snap button + Intensity/LM knob	Long press **:	Enables/disables Light Manager (LM): - Disabling: The indicator light blinks GREEN / ORANGE / GREEN in sequence. - Enabling: The indicator light blinks GREEN / GREEN / GREEN in sequence.

* Short press means: hold less than 1 second, then release.

** Long press means: hold at least 1.5 seconds.

*** BLINK: the indicator light alternately goes on/off at 500 ms intervals

2.5 Control and functional elements on microscope components

2.5.1 Binocular tubes/photo tubes

The appropriate adapters for reflex cameras, microscope cameras and video cameras may be plugged into the camera port (Fig. 2-8/1, Fig. 2-9/1 or Fig. 2-10/2) of the binocular photo tubes.

Binocular photo tube 30°/20 with fixed graduation 50:50

Fifty percent of the light is directed to the eyepieces and fifty percent to the camera port (Fig. 2-8).

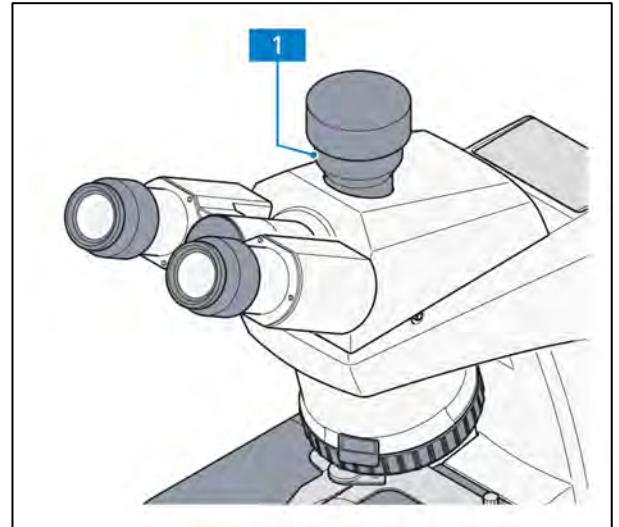

Fig. 2-8 Binocular photo tube 30°/23 with fixed graduation 50:50

Binocular photo tube 20°/23 upright image with toggle graduation 100:0/0:100

The light can be directed using the slider to either the eyepieces or the mounted camera.

- Slider (Fig. 2-9/2) pushed in: 100% light to eyepieces.
- Slider (Fig. 2-9/2) pulled out: 100% light to camera.

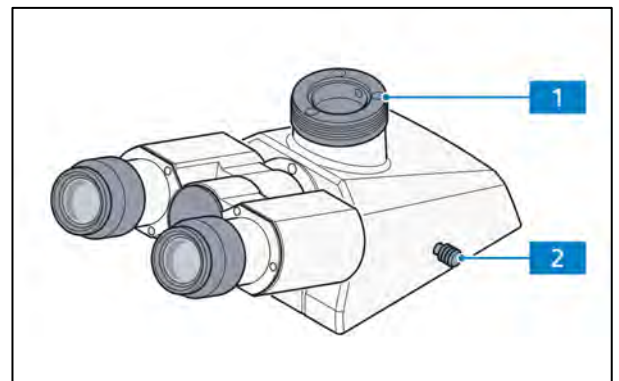

Fig. 2-9 Binocular photo tube 20°/23 with toggle graduation 100:0/0:100



NOTE

For polarization microscopy, we recommend using the Pol photo tube with upright image and one eyepiece reticle (graticule).

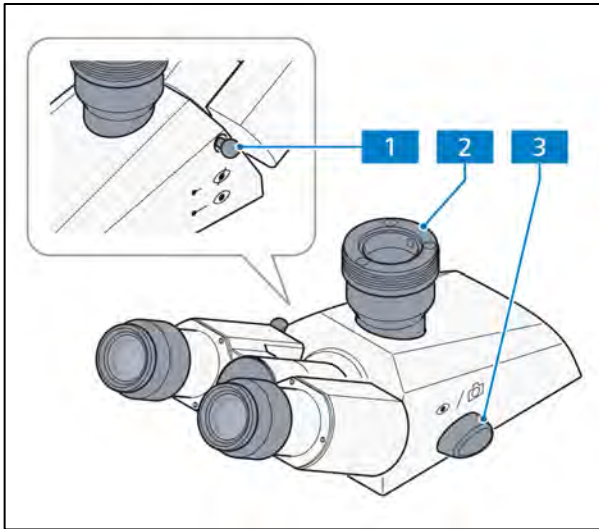

Fig. 2-10 Binocular photo tube 30°/23 with toggle graduation 100:0/0:100

Binocular photo tube 30°/23 (100:0/0:100)

The light can be directed using a shift knob to either the eyepieces or the mounted camera.

- Shift knob (Fig. 2-10/3) to front (eye symbol):
100% light to eyepieces.
- Shift knob (Fig. 2-10/3) to the rear (camera symbol):
100% light to camera.
- Push-pull rod (Fig. 2-10/1) pushed in: eyepiece shutter closed.
- Push-pull rod (Fig. 2-10/1) pulled out: eyepiece shutter opened.
- Particularly for camera shots with extended exposure times, it is recommended that possible residual light incidence through the eyepiece is prevented either by means of an eyepiece shutter or eyepiece cover (included in dust guard set). If neither is available, remove the eyepiece and attach the supplied dust cap to the eyepiece barrels!

Binocular ergo tube/ergo photo tube 20°/23

The ergo tube is designed for the 23 mm field of view. For use on the Axiolab 5 it is recommended for a maximum field of view of 22 mm. The viewing angle is 20°.

The ergo photo tubes are equipped with a camera port (Fig. 2-11/1).

The camera ports can be used to mount a reflex camera, a microscope camera or a video camera with the aid of appropriate adapters.

The camera port may carry a maximum weight of 2.5 kg (camera plus cable). For a fee, the ZEISS service personnel will equip your instrument with a higher maximum load, if needed.

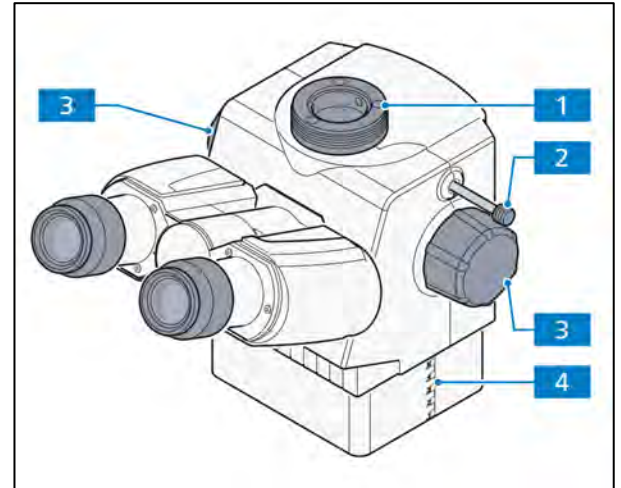

Fig. 2-11 Binocular ergo photo tube 20°/23 with vertical adjustment

The ergo tubes allow a height adjustment range of 44 mm.

A larger range of adjustment can be used by swiveling the binocular section from the lower to the upper observation position (depending on inter-pupillary distance).

- Continuous vertical adjustment by means of the rotary knobs (Fig. 2-11/3).
- The adjustment range can be read off the vertical scale (Fig. 2-11/4).

The ergo photo tube has two switch settings (Graduation: 100:0/0:100).

- Push-pull rod (Fig. 2-11/2) pushed in: 100% to the eyepieces
- Push-pull rod (Fig. 2-11/2) pulled out: 100% to the camera port

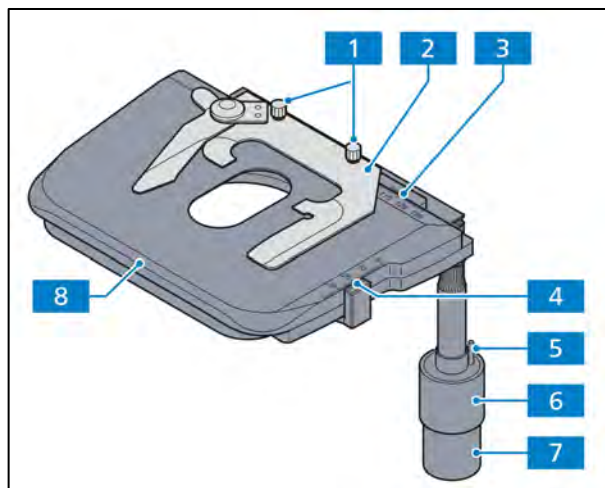

Fig. 2-12 Mechanical stage 75x50 R with specimen holder

2.5.2 Microscope stages

Mechanical stage 75x50 R or L or mechanical stage 75x30 R ergonomic with stationary drive

- Mechanical stage (Fig. 2-12/8) for holding and positioning specimens with a specimen holder.
- Specimen holder (Fig. 2-12/2) for single-handed operation or specimen holder for counting chambers (replaceable after loosening the two knurled screws, Fig. 2-12/1).
- Coaxial knurled knobs for X (Fig. 2-12/7) and Y adjustment (Fig. 2-12/6). The coaxial knurled knobs for X and Y can be adjusted to suit the personal preferences of the user with regard to height and friction. The required tools (Fig. 2-12/5) are located in the upper coaxial knurled knob.
- Vernier scale for display of adjustment range in the X (Fig. 2-12/3) and Y directions (Fig. 2-12/4).
- Coaxial knurled knobs on right (R) or left (L) side depending on the model.

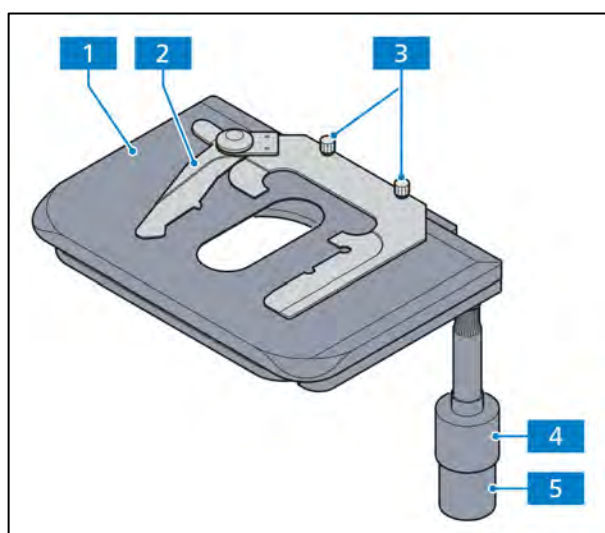

Fig. 2-13 Mechanical stage 75x50 R with specimen holder

Mechanical stage 75x50 R or L

- Mechanical stage (Fig. 2-13/1) for holding and positioning specimens with a specimen holder.
- Specimen holder (Fig. 2-13/2) for single-handed operation or specimen holder for counting chambers (replaceable after loosening the two knurled screws, Fig. 2-13/3).
- Coaxial knurled knobs for X (Fig. 2-13/5) and Y adjustment (Fig. 2-13/4).
- Coaxial knurled knobs on right (R) or left (L) side depending on the model.

Mechanical stage for reflected light 75x30 R

- Mechanical stage (Fig. 2-14/2) for holding and positioning specimens with specimen holding plate (Fig. 2-14/1) with spring clips.
- Coaxial knurled knobs for X and Y adjustment on right-hand side.
- Vernier scale for display of the adjustment range in the X and Y directions.
- Removable specimen-holding plate (simply unscrew the two knurled screws to remove it).

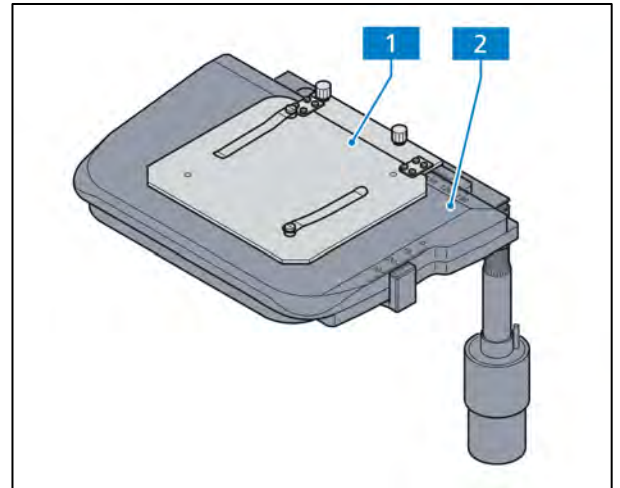

Fig. 2-14 Mechanical stage for reflected light 75x30 R with specimen-holding plate

Rotary stage Pol 360° with lock

- The Pol rotary stage for holding and positioning specimens with specimen guide (Fig. 2-15/4) and specimen holder (Fig. 2-15/6) accommodates standard 45x25 mm slides and 75x25 mm (3"x1").
- 360° rotation with lock (use knurled screw to lock) (Fig. 2-15/5).
- Click stop (Fig. 2-15/7) every 45°; enabled or disabled via the control knob (Fig. 2-15/8).
- The specimen guide (Fig. 2-15/4) can be removed by unscrewing the two clamp screws with an Allen wrench (AF 2), Fig. 2-15/3; two cylindrical pins on the underside serve as orientation for mounting the specimen guide on the rotary stage).
- The specimen guide is equipped with a specimen holder that can be shifted in the X and Y directions using the coaxial knurled knobs (Fig. 2-15/2 and 1). The shifts in the X and Y directions can be read off the respective Vernier scale.

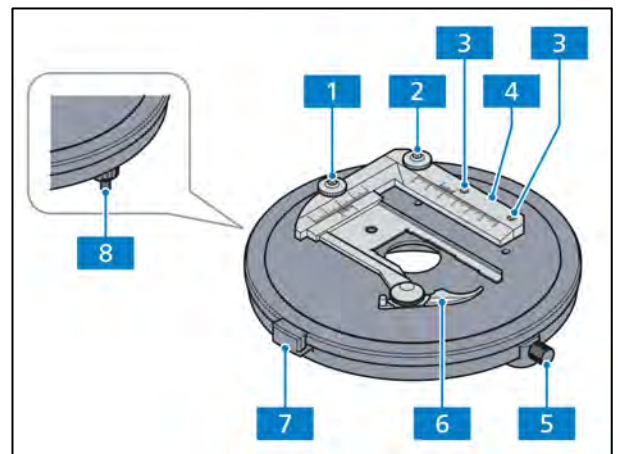

Fig. 2-15 Pol rotary stage

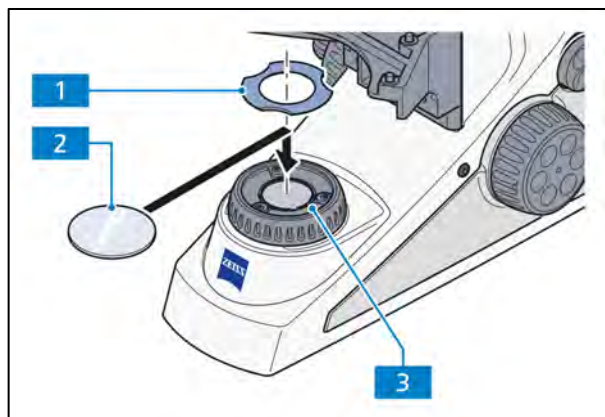

Fig. 2-16 Filter mount on luminous-field diaphragm operating ring for filter $d=32 \times 4$ mm

2.5.3 Filter mount on luminous-field diaphragm operating ring for filter 32×4 mm

- Place the filter (Fig. 2-16/2) on the luminous-field diaphragm operating ring (Fig. 2-16/3).
- To secure the filter, insert the filter clamp (Fig. 2-16/1) on the luminous-field diaphragm operating ring.
- To replace the filter, grip the recesses of the filter clamp and pull it off the luminous-field diaphragm operating ring.

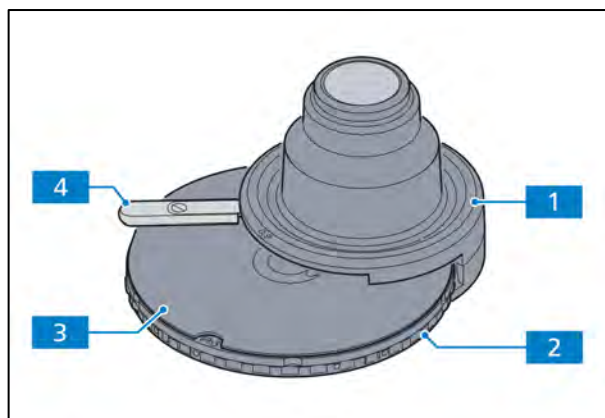

Fig. 2-17 Condenser 0.9/1.25 BF, DF, Ph1, Ph2, Ph3 with modulator disk

2.5.4 Condensers

Condenser 0.9/1.25 BF, DF, Ph1, Ph2, Ph3

Condenser 0.9/1.25 BF (Fig. 2-17/1) with aperture diaphragm (Fig. 2-17/4) with modulator disk (Fig. 2-17/3) for:

- brightfield microscopy (BF)
- darkfield microscopy (DF)
- phase contrast microscopy (Ph 1, Ph 2, Ph 3)

Adjust the position of the modulator disk by turning the knurled ring (Fig. 2-17/2).

This condenser is also available without a modulator disk, i.e. only for brightfield microscopy.

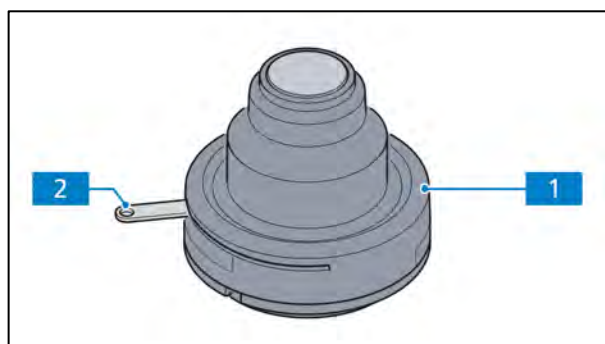

Fig. 2-18 Condenser 0.9/1.25 BF

Condenser 0.9/1.25 BF

Condenser 0.9/1.25 BF (Fig. 2-18/1) with aperture diaphragm (Fig. 2-18/2) for brightfield microscopy.

This condenser is also available with a modulator disk.

2.5.5 Filter slider for reflected light stand

- Filter slider for reflected light with two positions for filters with a diameter of 25 mm (neutral and color filters, white balance filter)
- Insert the filter slider from the left and operate (Fig. 2-7/5)

2.5.6 Reflector turret with 4 positions

The 4-position reflector turret is equipped with push-and-click (P&C) reflector positions.

The reflector position is adjusted by turning the knurled ring (Fig. 2-19/1). The marking (Fig. 2-19/2) on the knurled ring shows the reflector position in the beam path.

The stickers supplied can be used to identify the reflector modules used. The stickers can be applied to the areas provided (Fig. 2-19/3).

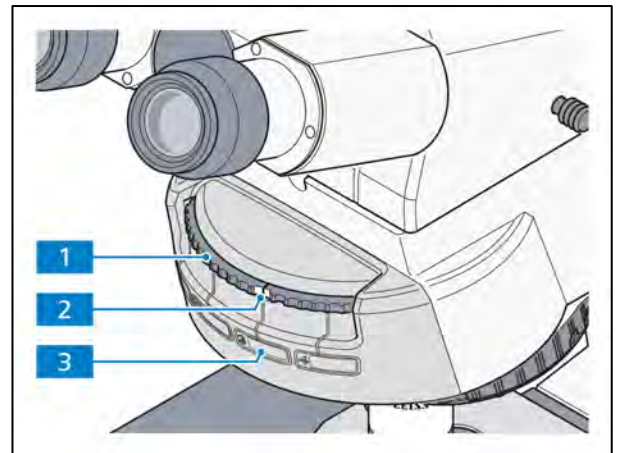

Fig. 2-19 4-position reflector turret

2.5.7 Low-power system for objectives 2.5x/4x

The low-power system is for full display field illumination when using an objective with a weak magnification factor (2.5x–4x) in combination with the Abbe condenser 0.9/1.25 H.

It can be centered and remains swiveled into the beam path for as long as the respective objective is in use.

- Swivel the low-power system (Fig. 2-20/2) into/out of the beam path using the handle (Fig. 2-20/1). Ensure that the low-power system snaps in securely when swiveled in.

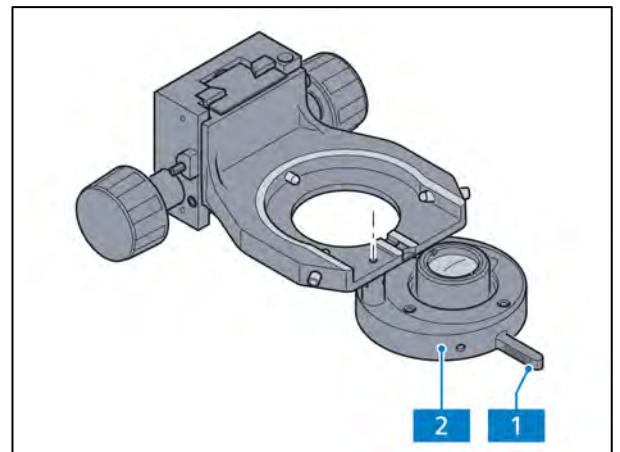

Fig. 2-20 Low-power system

The illumination of weak objective magnifications can be centered with the centering screws. For this purpose, the condenser should be centered on the other objectives without the low-power system.



ATTENTION

If the condenser carrier with mounted low-power system is moved too far down, the low-power system may collide with the field diaphragm and damage it!

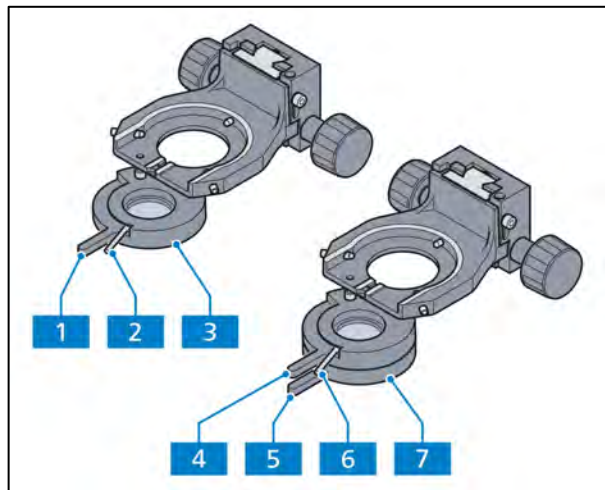

Fig. 2-21 Polarizers

2.5.8 Polarizer

Polarizer D, 90° rotatable, switchable (Fig. 2-21/3)

- Polarizer can be swiveled in/out using handle (Fig. 2-21/1)
- Polarizer with lever (Fig. 2-21/2), 90° rotatable

Polarizer, fixed with lambda plate, rotatable, (Fig. 2-21/7)

- Polarizer can be swiveled in/out using handle (Fig. 2-21/5)
- Lambda plate can be swiveled in/out using handle (Fig. 2-21/4)
- Lambda plate with lever (Fig. 2-21/6), rotatable



ATTENTION

If the condenser carrier with mounted polarizer is moved too far down, the polarizer may collide with the field diaphragm and damage it!

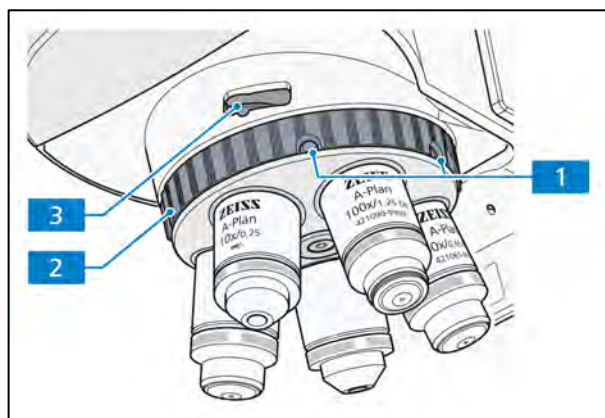

Fig. 2-22 Nosepiece of the transmitted/
reflected light polarization stand
with mount for compensators

2.5.9 Nosepiece with objectives

- Nosepiece 5x with M27 threaded insert for five objectives.
- You can change the objectives quickly by turning the nosepiece on knurled ring (Fig. 2-22/2).
- Incorporates slot (Fig. 2-22/3) for 6x20mm slider (compensators, analyzers, quarter plates).
- Stand for transmitted light polarization and stand for transmitted light conoscopy with 5_position nosepiece, of which one position is fixed and four positions can be centered with the aid of two screws each (Fig. 2-22/1).



ATTENTION

Do not overtighten the screws (Fig. 2-22/1) on the stop.

2.5.10 Microscope operating modes

2.5.10.1 Using the microscope imaging system as a standalone system

The microscope with Axiocam 208/202 can be used in standalone mode. The camera acts as the control interface and is powered by microscope via the USB (Commercial Micro-D power) cable. A USB Type-C drive is included in the package and can be connected via the USB slot at the back of the camera for storing data. Then images are recorded and saved to the USB drive. Functions of the microscope stand such as the Light Manager and encoding are automatically launched. The camera is equipped with image enhancement functions such as true color and noise reduction.



NOTE

Please note that the focus plane of the camera must be adjusted to the focus plane of the eyepieces via the camera adapter.

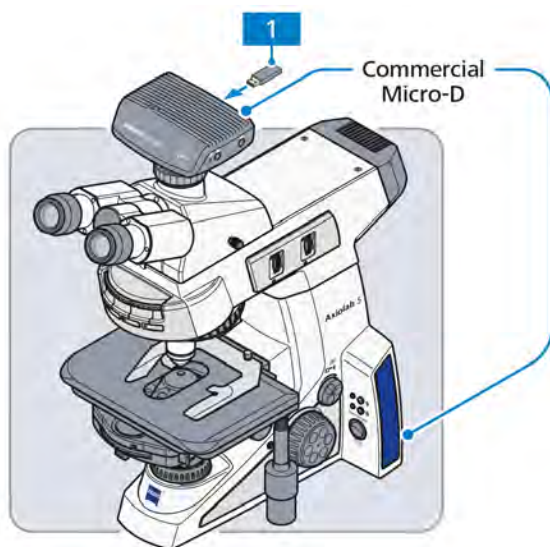

1 USB Type-C drive included in package

Functionality:

- Light Manager
- Coded components
- Image enhancement (true color, noise reduction)
- Snap and save image on USB drive
- Record and save movie on USB drive



NOTE

- Currently the snap button on the stand functions only with the Axiocam 208/202. It cannot be used with any other cameras.
- The snap button on the stand works only when a USB drive is detected by the camera port.

2.5.10.2 Connecting the microscope to an HD monitor, TV or projector via an HDMI cable

A monitor can be connected to the camera via an HDMI cable. The camera is powered by the microscope via the USB (Commercial Micro-D power) cable. A USB hub can be connected via the USB port on the camera. A wireless or wired mouse and keyboard can be connected to the camera via the USB hub, which together with the monitor, act as the control interface. Functions such as the Light Manager, encoding and image enhancement are automatically deployed. Live images can be viewed on the monitor display and advanced features are available in OSD (on-screen display). With Axiolab 5 TL/FL, One-key fluorescence function can be used. Images can be snapped and saved into the USB Type-C drive, which is connected via the USB hub.

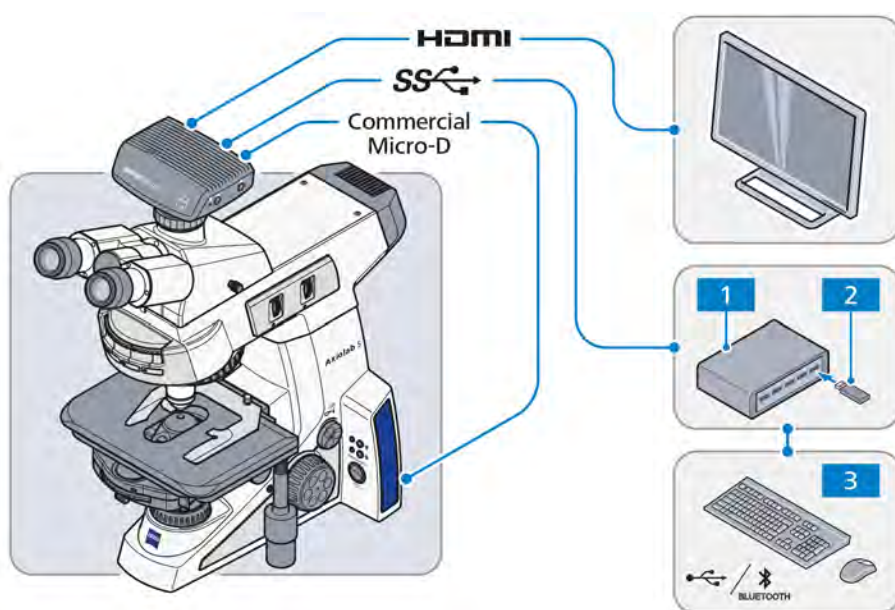

Functionality :

- Light Manager
- Coded components
- Image enhancement
- Observe live image on display
- Snap and save image on the USB drive
- Record and save movie on the USB drive
- One-key fluorescence*
- Advanced features in OSD

*: This works only with Axiolab TL/FL

- 1 USB hub (input type C to output type A)
- 2 USB Type-C drive provided in package
- 3 Mouse keyboard

2.5.10.3 Using the microscope imaging system with Labscope/Matscope via a Wi-Fi dongle connection

The camera is powered by the microscope via a USB (Commercial Micro-D power) cable. An optional monitor can be connected to the camera via an HDMI cable. The recommended USB Wi-Fi dongle can be connected to the camera via the USB hub. The control interface can be a PC or portable electronic device that uses Wi-Fi. Functions such as the Light Manager, encoding, ECO mode and image enhancement are automatically launched. When a monitor is connected, live images can be viewed on the monitor display. Live images can also be viewed on PC or portable devices and advanced features in Labscope/Matscope are available. With Axiolab 5 TL/FL, the one-key fluorescence function can be used.

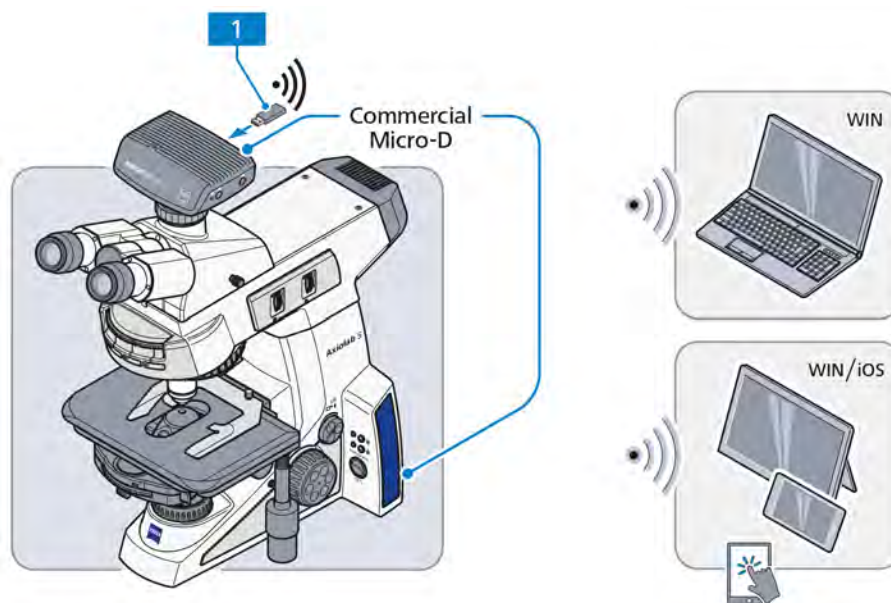

Functionality:

- Light Manager
- Coded components
- ECO mode
- Image enhancement
- Observe live image
- Snap and save image via software
- One-key fluorescence*
- Advanced features in Labscope/Matscope

*: Only with specific microscopy configuration

- 1 USB Wi-Fi dongle (please see the ZEISS website for the recommended model)

2.5.10.4 Using the microscope imaging system with Labscope/Matscope via a WLAN router connection

The camera is powered by the microscope via a USB (Commercial Micro-D power) cable. An optional monitor can be connected to the camera via an HDMI cable. A router is connected to the camera via Ethernet. The control interface can be a PC or portable electronic device controlled via Ethernet or Wi-Fi. Functions such as the Light Manager, encoding, ECO mode and image enhancement are automatically launched. When a monitor is connected, live images can be viewed on the monitor display. Live images can also be viewed on a PC or a portable device and advanced features in Labscope/Matscope are available. With Axiolab 5 TL/FL, the one-key fluorescence function can be used.

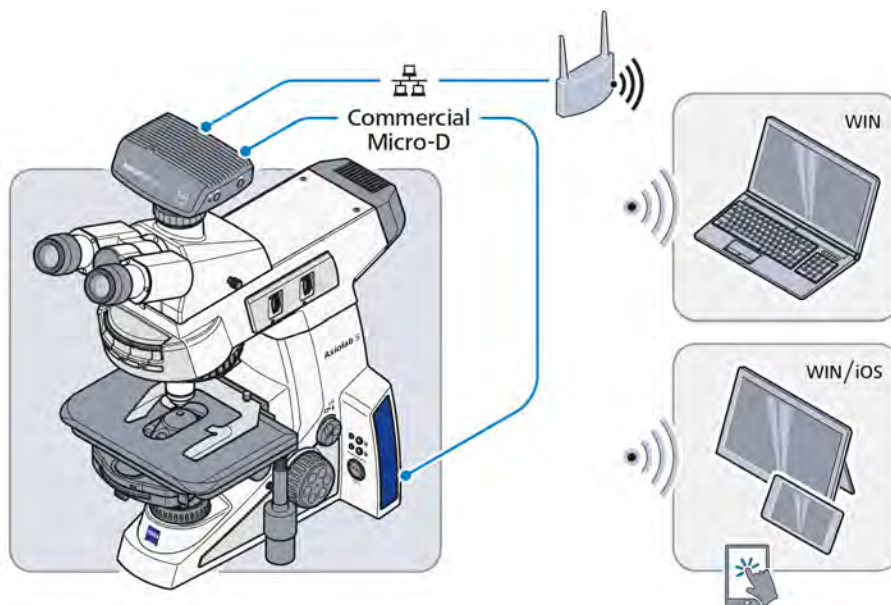

Functionality:

- Light Manager
- Coded components
- ECO mode
- Image enhancement
- Observe live image
- Snap and save image via software
- One-key fluorescence*
- Advanced features in Labscope/Matscope

*: Only with specific microscopy configuration

2.5.10.5 Using the microscope imaging system with Labscope/Matscope via a USB connection

The camera is powered by the microscope via a USB (Commercial Micro-D power) cable. An optional monitor can be connected to the camera via an HDMI cable. A PC or Windows Surface can be connected to the camera via a USB cable. Functions such as the Light Manager, encoding, ECO mode and image enhancement are automatically launched. When a monitor is connected, live images can be viewed on the monitor display. Live images can also be viewed on a PC or Surface and advanced features in Labscope/Matscope are available. With Axiolab TL/FL, the one-key fluorescence function can be used.

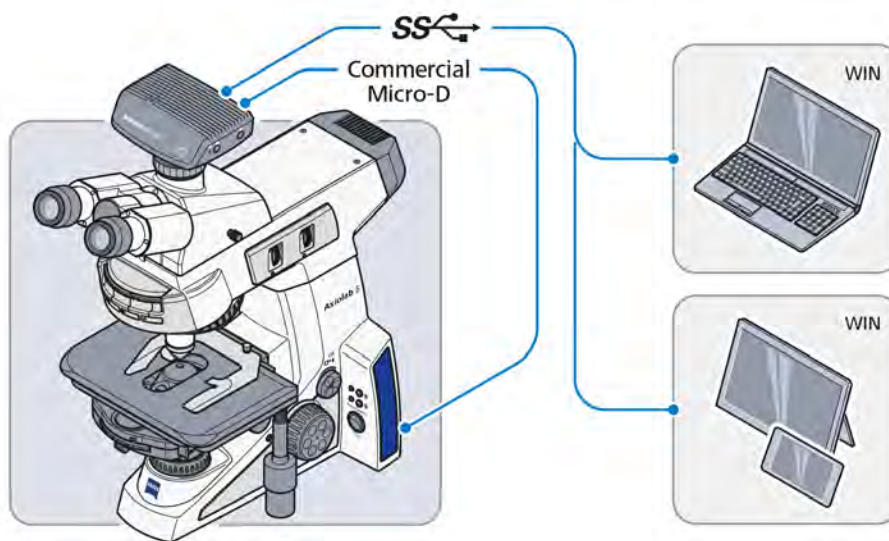

Functionality:

- Light Manager
- Coded components
- ECO mode
- Image enhancement
- Observe live image
- Snap and save image via software
- One-key fluorescence*
- Advanced features in Labscope/Matscope

*: Only with specific microscopy configuration

2.5.10.6 Using the microscope imaging system with ZEN software via a USB connection

The camera is powered via a USB (Commercial Micro-D power) cable connected to an external power socket. A workstation can be connected to the camera and the microscope stand via USB cables at the same time. Functions such as the Light Manager, encoding and ECO mode are automatically launched. Live images can also be viewed on the workstation and basic features in ZEN are available.

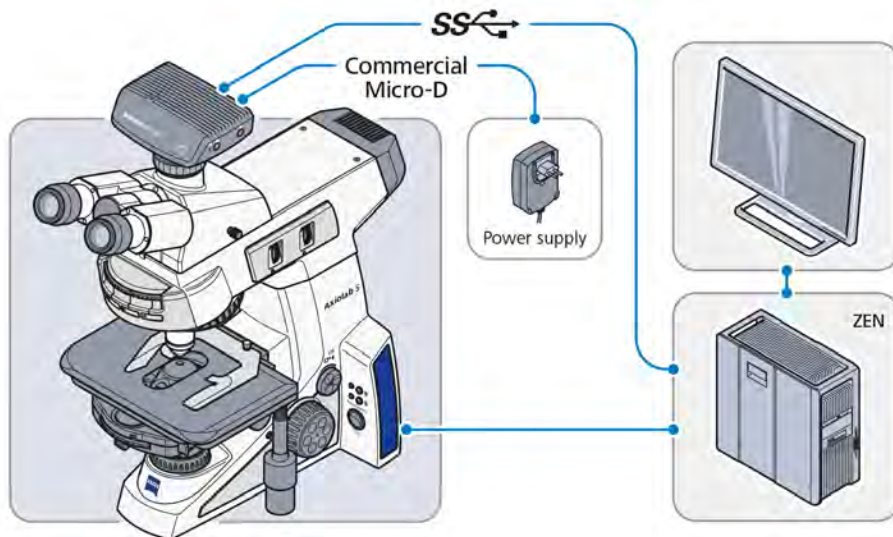

Functionality:

- Light Manager
- Coded components
- ECO mode
- Image enhancement
- Observe live image
- Snap and save image via software
- Basic features in ZEN

2.5.11 Axiocam 202 mono/208 color controls and connectors

The camera connection panel contains the following connectors (see Fig. 2-23):

- 1 port for power supply and communication to the microscope stand (via Commercial Micro-D cable)
- 2 port for camera control and image transfer (USB 3.0)
- 3 Gigabit Ethernet port (RJ45) for communication and image transfer
- 4 HDMI port for image data transfer to a monitor, TV or projector

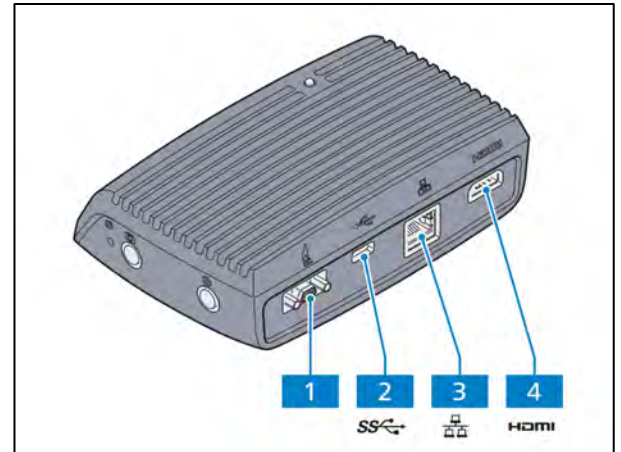



Fig. 2-23 Camera connection panel (rear side)

The Axiocam control panel contains the following elements (see Fig. 2-24):

- 1 camera factory reset button
- 2 image/video capture button (
- 3 OSD menu button
- 4 status LED

	NOTE
For more information about OSD see the Axiocam 202/208 User Guide.	

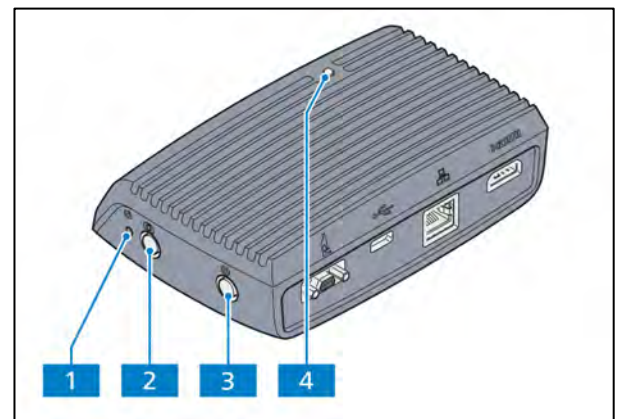

Fig. 2-24 Camera operator panel (right side)

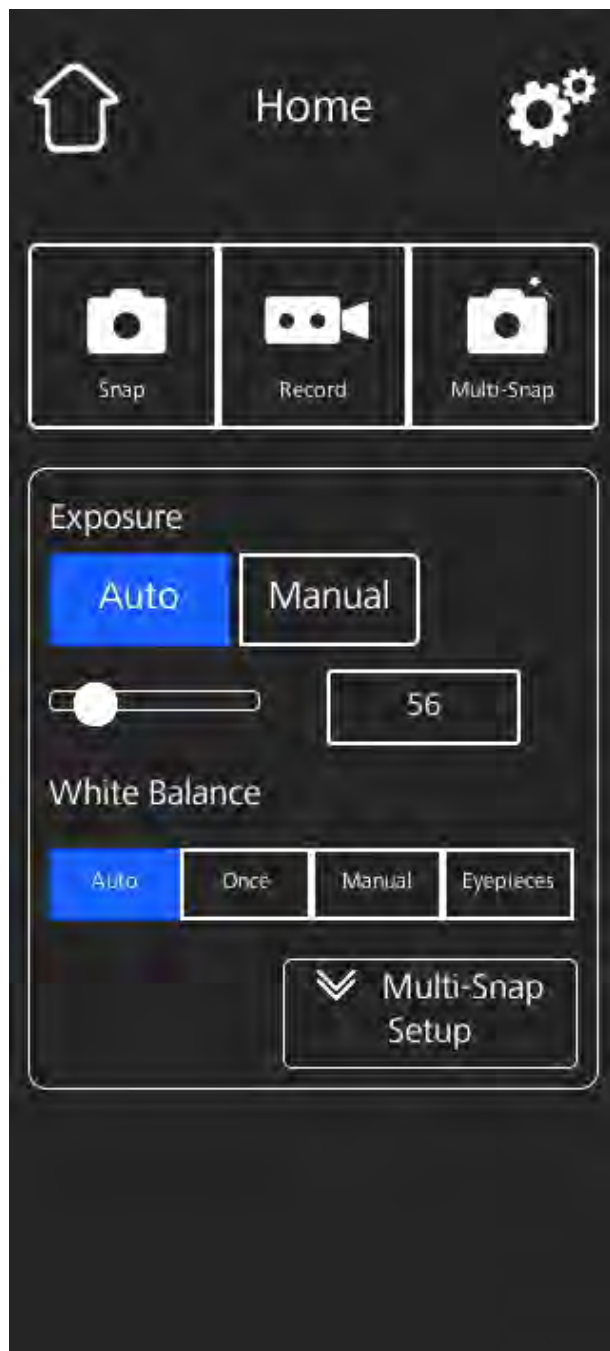



Fig. 2-25 OSD menu, Home

2.5.12 OSD functionality with Axiocam 202 mono/208 color

The On Screen Display menu (OSD menu) is shown on whatever display the camera is connected to via an HDMI cable.

- Press the **OSD menu** button (Fig. 2-24/3) to open the menu (see Fig. 2-25).

	NOTE For more information about OSD functionality, see the Axiocam 202/208 User Guide.
---	--

3 START-UP

The Axiolab 5 microscopes can be independently installed, converted and started up by the customer. On request, the microscope can also be installed or converted by ZEISS Service for an extra charge.



NOTE

Before installing and starting up the microscope, read the **Notes on instrument safety** (see section 1.1) carefully and thoroughly.

The assembly activities described in the following section are illustrated using examples for one microscope stand type. However, they apply similarly to other microscope stand models. Special features are described separately.

3.1 Mounting standard components

3.1.1 Unpacking and setting up microscope stand

- Remove all components from the packaging and check that all components described on the delivery note are present.
- Set up the microscope stand (Fig. 3-1/1) on a vibration-free, level, hard and non-combustible surface.
- Keep the original packaging for storage or for returning the instrument to the manufacturer, or dispose of it properly.

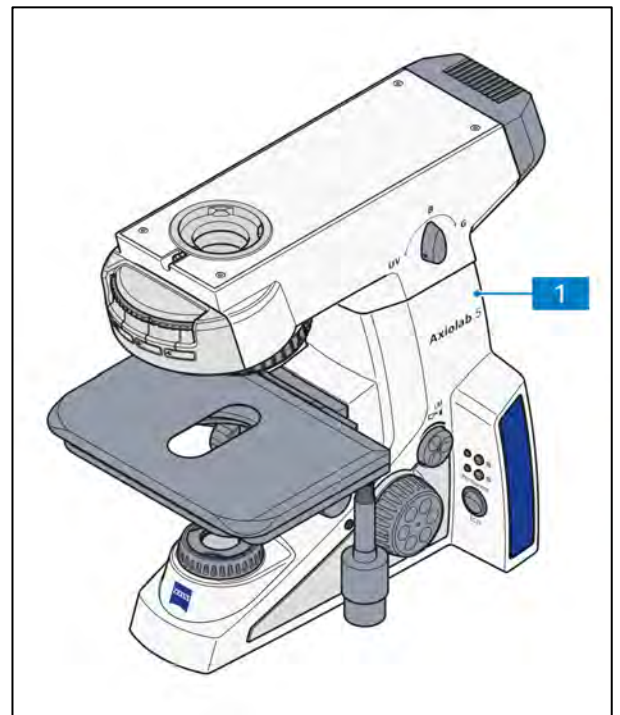

Fig. 3-1 Setting up the microscope

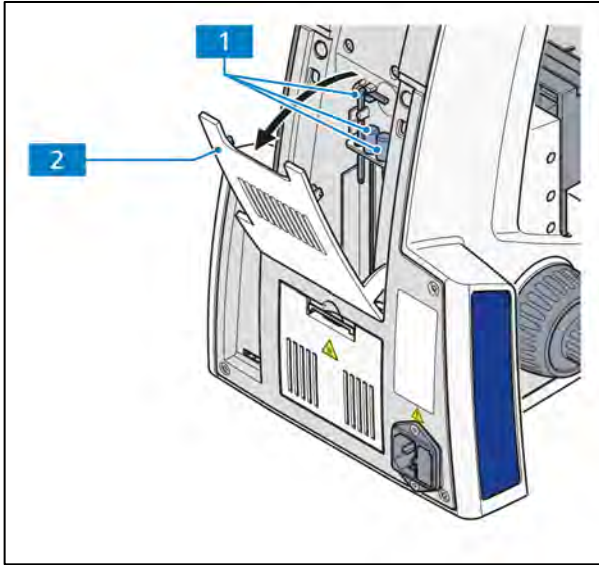

Fig. 3-2 Placing tools in the storage compartment

- The tools (Fig. 3-2/1) required for set-up and adjustment of the microscope are located in the storage compartment (Fig. 3-2/2) at the back of the stand.
- Pull the cover flap to open it, push it to close.

The following tools are included in the delivery:

- angled Allen wrench (AF 3)
 - two knurled Allen wrenches (AF 1.5) for adjusting the phase contrast diaphragms in the respective condenser positions.
-
- For shipping, the power cord can be rolled up and stowed in the open cover flap.

3.1.2 Attaching the binocular tube/photo tube

For tubes mounted **without** an intermediate plate, proceed as follows:

- Loosen the screw (Fig. 3-3/4) with an Allen wrench (AF 3). Remove the dust caps (Fig. 3-3/2, 5) from the underside of the tube and the dovetail ring mount on the stand side.
- Hold the binocular tube/photo tube (Fig. 3-3/1) at an angle, insert it with the dovetail ring into the stand mount (Fig. 3-3/3) and turn into a horizontal position. Rotate the binocular tube into the desired observation position and re-tighten the Allen screw with the Allen wrench.

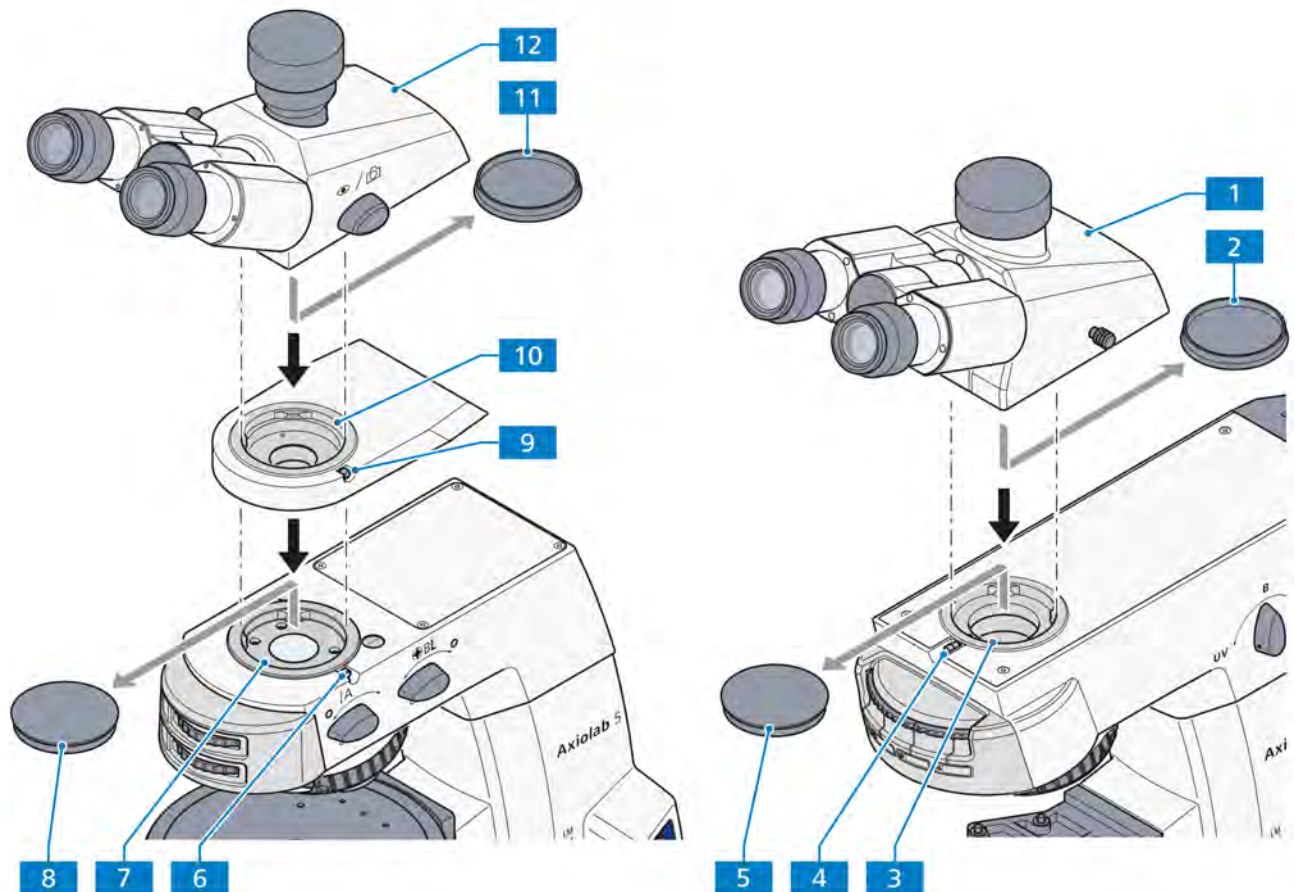

Fig. 3-3 Attaching the binocular tube

For tubes mounted **with** an intermediate plate on the Axiolab 5 stand, Pol-TL/conoscopy (430037-90042-000), proceed as follows:

- Loosen the screw (Fig. 3-3/6) with an Allen wrench (AF 3). Remove dust caps (Fig. 3-3/8, 11) from the underside of the tube and the dovetail ring mount on the stand side.
- Insert the intermediate plate (Fig. 3-3/10) with its dovetail ring into the stand mount (Fig. 3-3/7) and tighten Allen screw (Fig. 3-3/6).
- Insert the binocular tube/photo tube (Fig. 3-3/12) into the intermediate plate, align and tighten the screw (Fig. 3-3/9) with the Allen wrench.

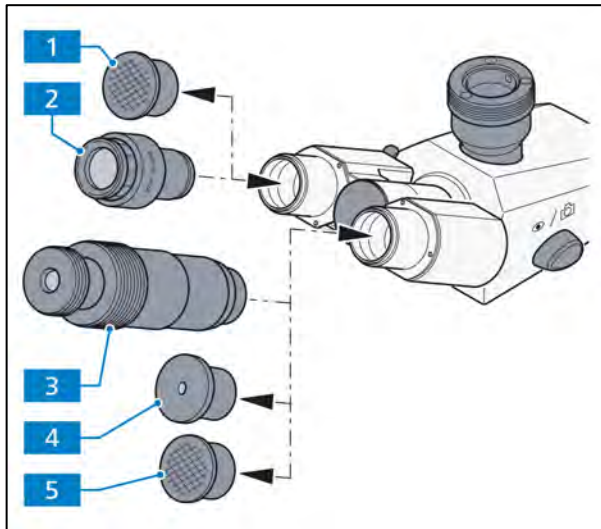



Fig. 3-4 Inserting eyepieces

3.1.3 Inserting eyepieces or auxiliary microscope or pinhole diaphragm

- Remove both dust caps (Fig. 3-4/1 and 5) from the binocular tube.
- Remove both eyepieces (Fig. 3-4/2) from the box and insert them into the binocular tube to the stop.

	<p>NOTE</p>
	<p>Before inserting Pol eyepieces with tubes without upright reticles, the orientation screw on the reverse side of the eyepieces must be unscrewed. The eyepieces cannot otherwise be fully inserted.</p>

- Instead of an eyepiece you may insert an auxiliary microscope (Fig. 3-4/3) into one of the binocular eyepiece tubes in order to observe aperture, phase and darkfield diaphragms and to center phase and darkfield diaphragms. These diaphragms can be focused with the adjustable eye lens of the auxiliary microscope.
- The auxiliary microscope (Fig. 3-4/3) or pinhole diaphragm (Fig. 3-4/4) can be used to observe conoscopic images.

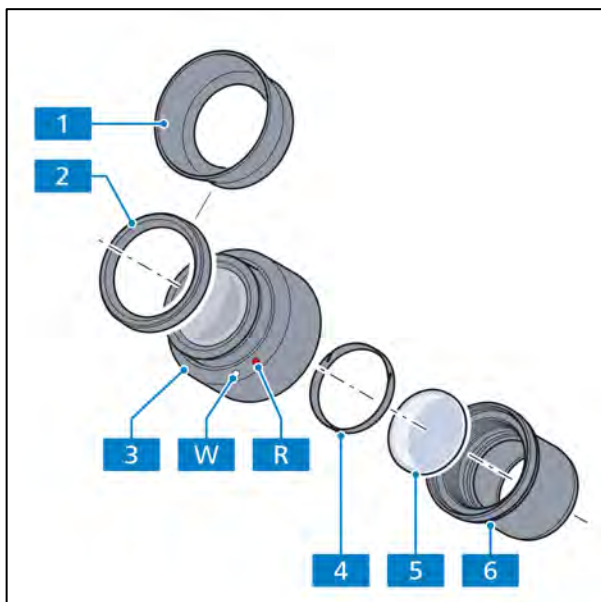

Fig. 3-5 Inserting the eyepiece reticle

Inserting the eyepiece reticle

Eyepiece reticles (Fig. 3-5/5) can be used with eyepieces (Fig. 3-5/3) marked with a red dot (Fig. 3-5/R).

- Unscrew mounting stop (Fig. 3-5/6) from the eyepiece (Fig. 3-5/3).
- Pull locking ring (Fig. 3-5/4) out.
- Insert eyepiece reticle (Fig. 3-5/5) into the mounting stop and fix it with the locking ring.
- Screw mounting stop (Fig. 3-5/6) into the eyepiece (Fig. 3-5/3).

Make sure that the side of the reticle (Fig. 3-5/5) with the line pattern on it is facing the mounting stop in the tube (Fig. 3-5/6) (the line pattern occurs mirror-inverted from the observer's point of view before the insertion). After insertion into the beam path of the microscope it is readable true to side.

The slight image shift caused by the additional path through glass is taken into account on the diopter scale by the fact that the zero point position is indicated not by the white dot (Fig. 3-5/W), but the red dot (Fig. 3-5/R).

	NOTE
	The eyepiece reticles must be inserted under dust-free conditions. This should be carried out only by ZEISS Service.

Inserting reversible eyecups

The eyepieces have rubber protection rings to avoid scratches on the eyeglasses. These may be replaced by reversible eyecups as desired.

- For this purpose, remove the eyeglass protection rings (Fig. 3-5/2) from the eyepieces and mount the eyecups (Fig. 3-5/1).

Sometimes the eyeglass protection rings are seated very tightly in the eyepiece groove, so you may need a blunt specimen (wooden stick) to prod them off.

3.1.4 Screwing in objectives

- Move mechanical stage with stage carrier to lower stop.
- Remove the dust protection caps (Fig. 3-6/5) from the appropriate openings in the nosepiece.
- Remove objectives (Fig. 3-6/4) from the case and screw them into the nosepiece (Fig. 3-6/1) starting with the smallest magnification factor (set up clockwise).
- Instead of an objective, the specimen marker (Fig. 3-6/3) with an adapter W0.8/M27 (Fig. 3-6/2) can be screwed on in any desired nosepiece position. If the specimen marker is not to be used for an extended period, apply the protective cap to prevent it from drying out.

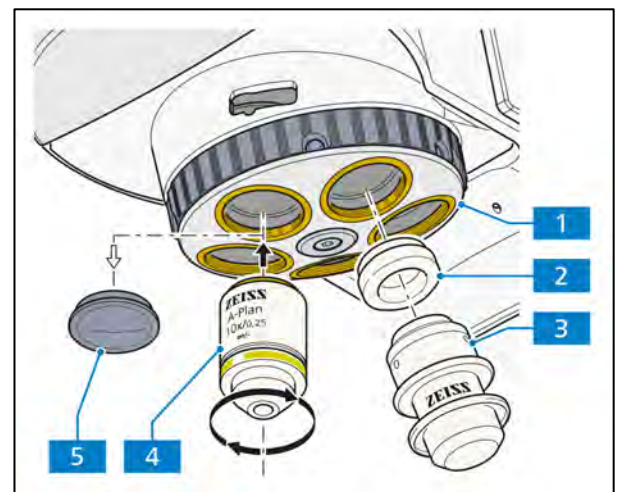



Fig. 3-6 Screwing in objectives

	NOTE
	Always replace the dust protection caps on any empty positions on the nosepiece.

	NOTE
	Adapter W0.8/M27 is required when using W0.8 objectives.

3.1.5 Inserting and removing P&C reflector modules in/from the reflector turret

The reflector turret with four positions is firmly installed in the reflected light illumination module for fluorescence or materials stands.

The modules must be inserted and removed from the front after removing the cover cap.

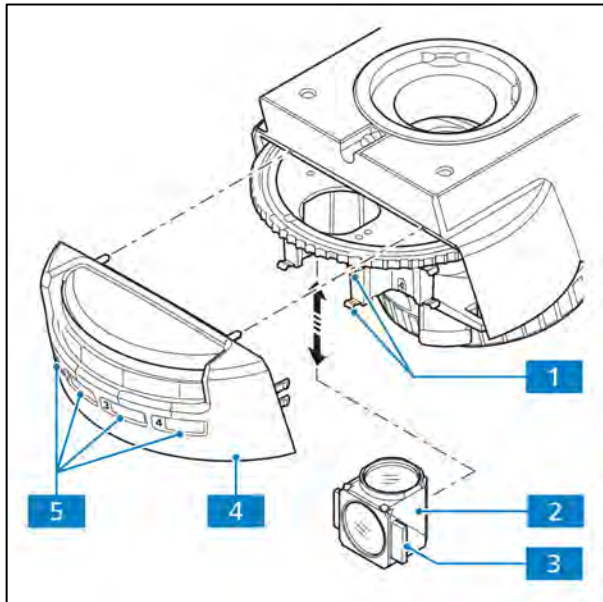

Fig. 3-7 Replacing the reflector module

Inserting a module:

- Remove the cover cap (Fig. 3-7/4) from the stand towards the front.
- Insert the module (Fig. 3-7/2) as illustrated together with the retaining brackets on the right and left (Fig. 3-7/3) diagonally from below into the upper spring clips (Fig. 3-7/1) of the reflector turret.
- Then apply pressure to the module from below until it also securely engages with the lower spring clips of the reflector turret. The position number of the P&C module is shown on the right hand side of the reflector turret adjacent to the position of the respective P&C module.
- Apply the supplied stickers with the filter combination data of the respective module to the corresponding field of the cover cap (Fig. 3-7/5, positions 1 to 4).

Removing a module:

- Slightly tilt the module in order to detach it from the lower spring clips, then from the upper spring clips of the reflector turret.
- Once the reflector modules have been installed / removed, refit the cover cap. The cover cap should be fitted onto the stand as straight as possible to avoid the knurled ring of the reflector turret becoming jammed and damaged.
- Apply pressure to the cover cap until the retaining brackets have engaged.

3.1.6 Mounting a mechanical stage

Axiolab 5 stands are fitted with the respective mechanical stage at the factory according to customer requirements.

The friction adjustment of the coaxial knurled knobs is set at an average value at the factory.

Should the stage need to be replaced or the stage settings changed, proceed as follows:

3.1.6.1 Dismantling a stage and specimen holder

- Loosen the two clamping screws (Fig. 3-8/1) of the specimen holder (Fig. 3-8/2) and take off the specimen holder.
- Remove the four fastening screws (Fig. 3-8/6) on the stage carrier (Fig. 3-8/4) using an Allen wrench (AF 3) (Fig. 3-8/5).
- Remove stage (Fig. 3-8/3) upwards from the stage carrier.

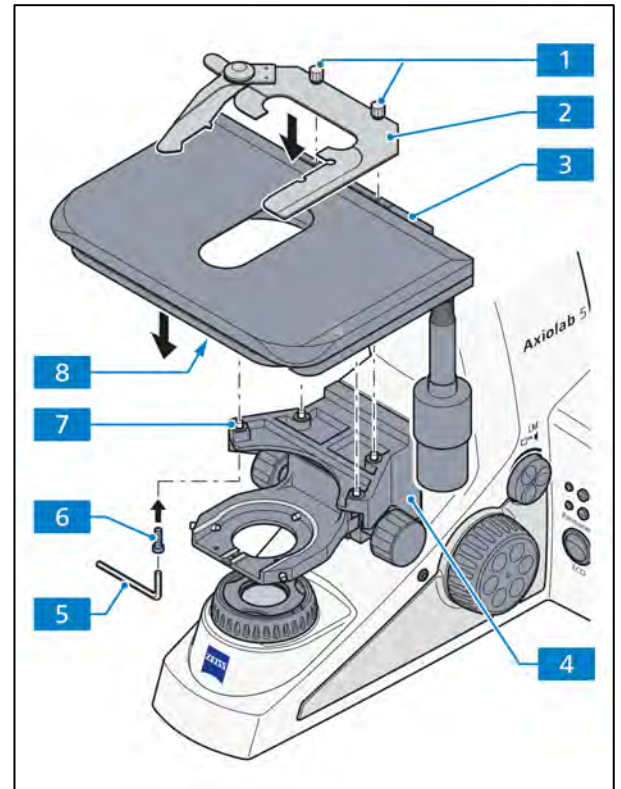

Fig. 3-8 Installing a mechanical stage

3.1.6.2 Installing the stage

- Place the stage (Fig. 3-8/3) on the stage carrier (Fig. 3-8/4) so that the threaded holes on the bottom of the stage (Fig. 3-8/8) are positioned above the stage carrier openings (Fig. 3-8/7).
- Insert four fastening screws (Fig. 3-8/6) through the stage carrier from below and screw them into the bottom of the stage.
- Turn the stage to orient it in an XY direction and tighten the fastening screws.
- Place the specimen holder (Fig. 3-8/2) on the stage and fasten the two clamping screws (Fig. 3-8/1).

3.1.6.3 Setting the drive length on stage drive

The length of the X and Y drives can be extended by shifting the respective coaxial knurled knob (Fig. 3-9/4 or 1) axially within a range of approx. 15 mm.

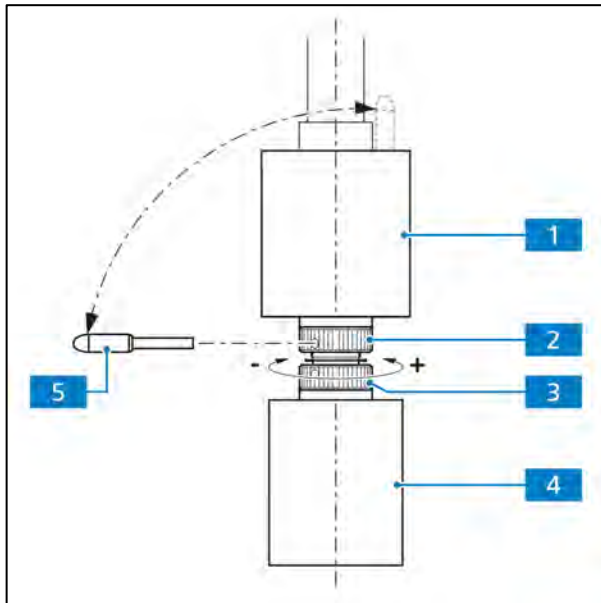

Fig. 3-9 Friction adjustment

3.1.6.4 Friction adjustment of coaxial knurled knobs for X/Y adjustment of the mechanical stage

(1) X drive

- Push the coaxial knurled knob for the X adjustment (Fig. 3-9/4) all the way to the bottom.
- Remove the supplied adjusting pin (Fig. 3-9/5) from the coaxial knurled knob for the Y adjustment (Fig. 3-9/1) and insert it into one of the holes of the lower hole nut (Fig. 3-9/3).
- Hold the coaxial knurled knob for the X adjustment (Fig. 3-9/4) and turn the hole nut with the adjusting pin clockwise (small friction adjustment: $-$) or counter-clockwise (large friction adjustment: $+$) until the desired freedom of movement has been achieved (see Fig. 3-9).
- It should not be shifted more than **one** revolution.

(2) Y drive

- Push the coaxial knurled knob for the Y adjustment (Fig. 3-9/1) all the way to the top.
- Insert the supplied adjusting pin (Fig. 3-9/5) into the hole of the upper hole nut (Fig. 3-9/2).
- Hold the coaxial knurled knob for the Y adjustment (Fig. 3-9/1) and turn the hole nut with the adjusting pin clockwise (small friction adjustment: $-$) or counter-clockwise (large friction adjustment: $+$) until the desired freedom of movement has been achieved.
- It should not be shifted more than **one** revolution.
- Re-insert the adjusting pin into the coaxial knurled knob for the Y adjustment (Fig. 3-9/1).



NOTE

Set the friction adjustment on the mechanical stage with the ergonomic, stationary XY drive analogously. No tool is required for the purpose. The lock-nut (silver) of the respective drive can be adjusted manually; hold the coaxial knurled knob tight.

3.1.7 Mounting the Pol rotary stage

3.1.7.1 Removing the Pol rotary stage

- Loosen the screw cap (Fig. 3-10/6) from the spring housing (about three rotations).
- Press the Pol rotary stage (Fig. 3-10/4) to the front against the spring-loaded pin (Fig. 3-10/7), lift it off the stage carrier (Fig. 3-10/5) from the back and remove it upwards.
- Re-tighten the screw cap (Fig. 3-10/6).

3.1.7.2 Attaching the Pol rotary stage

- Where necessary, loosen the screw cap (Fig. 3-10/6) of the spring housing with approx. three rotations.
- Place the Pol rotary stage with the groove of the dovetail (stage bottom) on the spring-loaded pin (Fig. 3-10/7).
- Attach the rotary stage with the clamp screw (Fig. 3-10/8) pointing to the front right.
- Press the Pol rotary stage to the front against the spring-loaded pin and lower it towards the back into the stage carrier (Fig. 3-10/5), then release it.
- Re-tighten the screw cap (Fig. 3-10/6).

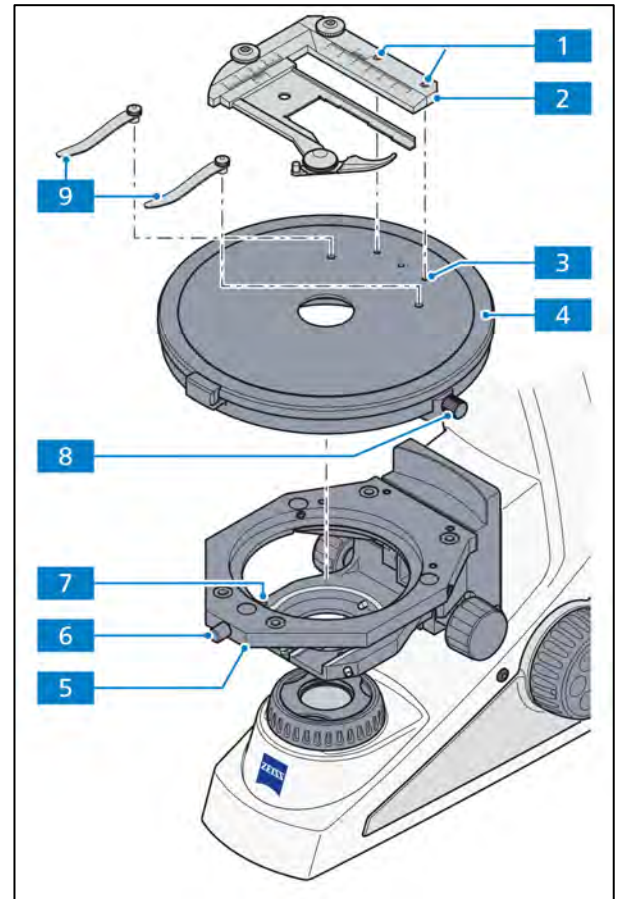

Fig. 3-10 Replacing the snap-in Pol rotary stage, detachable Pol specimen guide and stage clips



NOTE

The rotary stage must be mounted so that the vernier scale is on the left side and the clamp is on the right side.

3.1.7.3 Dismantling the detachable specimen guide and mounting stage clips

- Loosen the two clamp screws (Fig. 3-10/1) on the Pol specimen guide with an Allen wrench (AF 2). Remove the Pol specimen guide (Fig. 3-10/2) by lifting it upwards.
- Insert the stage clips (Fig. 3-10/9) into the holes provided.

3.1.7.4 Removing the stage clips and mounting the detachable Pol specimen guide

- Remove the stage clips (Fig. 3-10/9) from the Pol rotary stage.
- Insert the Pol specimen guide (Fig. 3-10/2) with the two cylindrical pins on the underside into the holes provided (Fig. 3-10/3) and tighten the two clamp screws (Fig. 3-10/1) with an Allen wrench (AF 2).

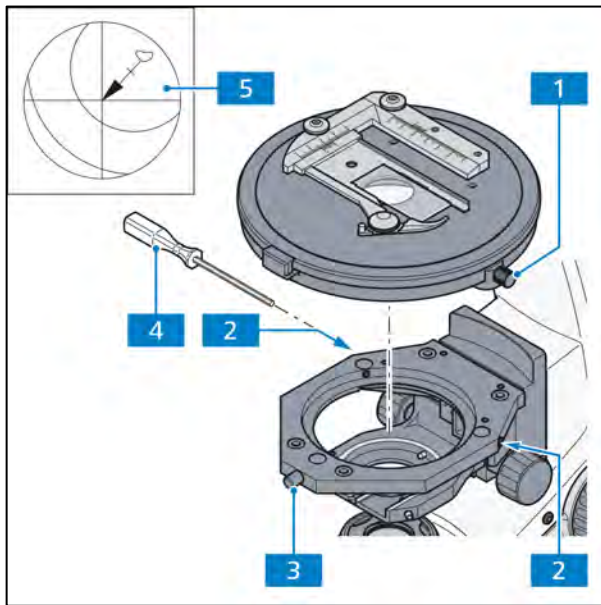

Fig. 3-11 Centering the Pol rotary stage

3.1.7.5 Centering the Pol rotary stage

With high-power objectives, centering can be exact only for one selected objective.

All stages are factory-precentered, i.e. while rotating the stage the specimen feature set to the center will remain in the center. If the specimen feature moves out of the center of the field of view (Fig. 3-11/5) while the stage is being rotated, the stage should be re-centered by following this procedure:

- The KÖHLER illumination on the microscope must be adjusted before centering the stage (see section 4.2.1).
 - Turn the nosepiece to swing the non-centering objective mount.
 - For centering the stage, use a contrasting specimen and an eyepiece with a crossline reticle.
- Loosen the stage clamping screw (Fig. 3-11/1) and the screw cap on the stage carrier (Fig. 3-11/3).
 - Rotate the stage to determine the position of maximum offset of the specimen feature (Fig. 3-11/5, origin of arrow) from the center of the eyepiece reticle.
 - Reset the two centering screws on the stage carrier (Fig. 3-11/2) using an Allen wrench (AF 1.5) (Fig. 3-11/4) to move the specimen detail by half an arrow length in the direction of the crossline center. Check whether the specimen detail moves when the stage is rotated again; repeat the procedure, if required.



NOTE

The Allen wrenches (AF 1.5) are located in the storage compartment at the back of the microscope stand.

- When centering is finished, re-tighten the screw cap (Fig. 3-11/3).

3.1.7.6 Centering the objectives of the polarization stand

The nosepiece 5x Pol is equipped with one fixed and four centerable objective positions.

Stage centering of the non-centering objective mount is necessary to ensure that a specimen feature located in the center of the field of view does not drift out while rotating the stage. By centering of the remaining objectives, the specimen feature remains in the center of the field of view even after changing the objective.

- The KÖHLER illumination on the microscope must be adjusted before centering the stage (see section 4.2.1).
- For centering the stage, use a contrasting specimen and an eyepiece with crossline reticle.
- First, turn the nosepiece to swing the non-centering objective mount. Center the rotary stage for the non-centering objective mount as described under 3.1.7.5.
- Turn the nosepiece to move a centering objective mount into the beam path.
- Rotate the stage to determine the position of maximum offset of the specimen feature (Fig. 3-12/3, origin of the arrow) from the center of the eyepiece reticle.
- Reset the two centering screws on the stage carrier (Fig. 3-12/2) using one AF 1.5 Allen wrench (Fig. 3-12/1) each to move the specimen detail by half the arrow length in the direction of the crossline center. Check whether the specimen detail moves when the stage is rotated again; repeat the procedure if required.
- Center the other three objectives in the same manner.

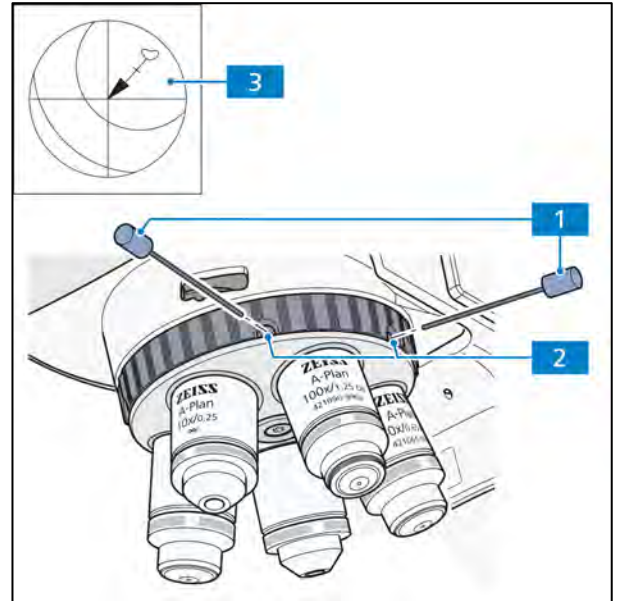

Fig. 3-12 Centering objectives



NOTE

To maintain this centering accuracy, when replacing an objective, do not hold the objective itself; hold the knurled ring of the nosepiece to rotate it.

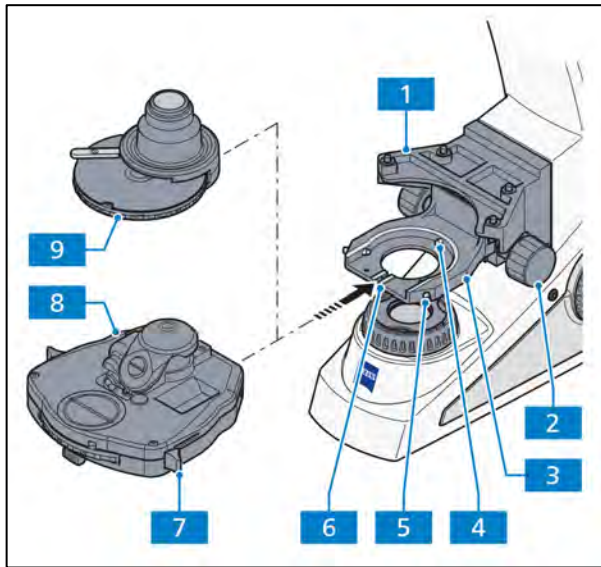

Fig. 3-13 Attaching the condenser

3.1.8 Mounting the condenser

- Move the stage carrier with the focusing drive to the higher stop position.



ATTENTION

The objectives should not collide with other parts.

- Swivel out the front lens (if shiftable) on the condenser using the lever (Fig. 3-13/7).
- Unscrew both centering screws (Fig. 3-13/5) on the condenser carrier until their ends are no longer visible.
- Using the knurled knob for vertical adjustment (Fig. 3-13/2), push the condenser carrier (Fig. 3-13/3) down as far as it will go. If using a low-power system, make sure that this does not come to rest on the luminous-field diaphragm.

- Insert the condenser (Fig. 3-13/8 or 9) between the condenser carrier (Fig. 3-13/3) and the stage carrier (Fig. 3-13/1). In doing so, align the screwed stud bolt on the underside of the condenser with the groove (Fig. 3-13/6).
- Press the condenser with the dovetail ring against the mainspring (Fig. 3-13/4) of the condenser carrier until the condenser sits horizontally on the condenser carrier.
- Position the condenser on the carrier so that the screwed stud bolt sits against the groove (Fig. 3-13/6) at the front.
- Insert the centering screws until they engage with the dovetail ring of the condenser.



NOTE

To mount other types of condensers, proceed in a similar manner.

3.1.9 Mounting the darkfield condenser

**NOTE**

The condenser holder Z for darkfield is required to place darkfield condensers in the condenser carrier.

- Insert the darkfield condenser (Fig. 3-14/6) in the condenser holder Z (Fig. 3-14/5) and screw on the fastening ring (Fig. 3-14/7)
- Push the condenser holder Z (Fig. 3-14/5) against the spring box (Fig. 3-14/2) into the condenser carrier (Fig. 3-14/1).
- Tighten both centering screws (Fig. 3-14/3) on the condenser carrier (Fig. 3-14/1) until they grip the dovetail ring of the condenser holder Z (Fig. 3-14/5).

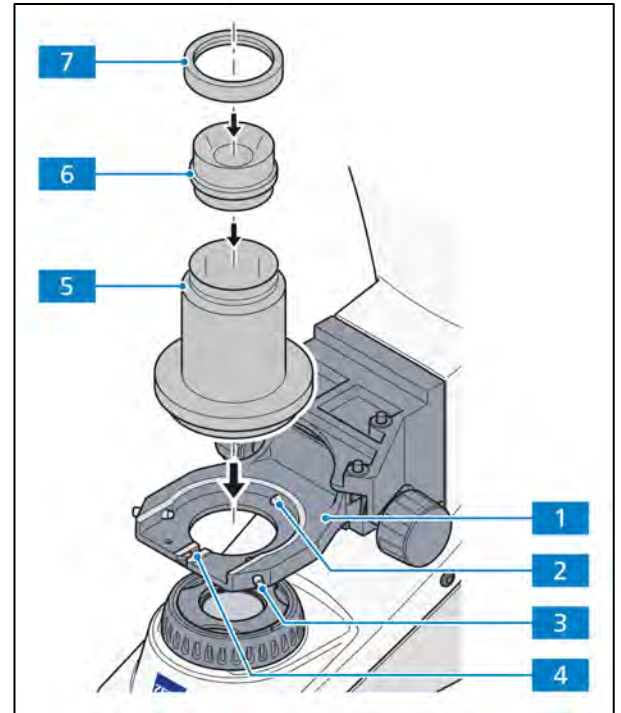

Fig. 3-14 Mounting the darkfield condenser

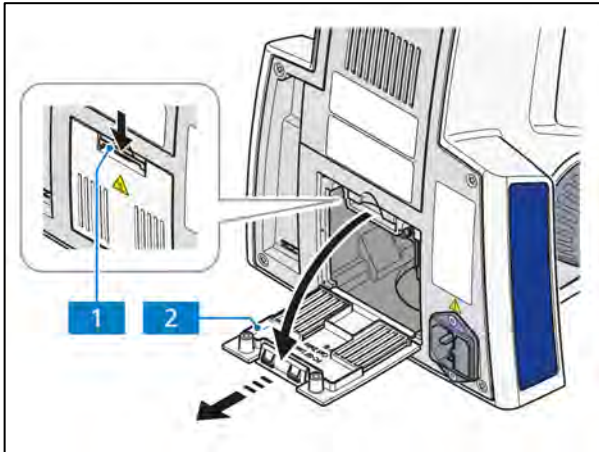

Fig. 3-15 Removing the cover

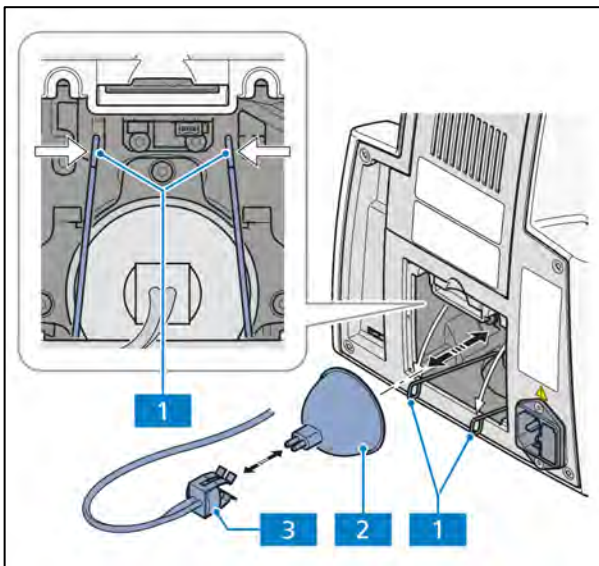

Fig. 3-16 Changing the halogen lamp

3.1.10 Mounting or replacing the 35 W halogen lamp or the 10 W LED illuminator for transmitted light

Axiolab 5 stands are equipped with a 10W LED white light for transmitted illumination. The LED illuminator can be alternatively changed to a 35W Halogen lamp.

To insert or replace the halogen lamp/LED illuminator, proceed as follows:

Removing the cover

- Switch off the microscope, remove the power cord on the microscope and allow it to cool down at least 15 min.
- Press the clamping jaw (Fig. 3-15/1) on the cover (Fig. 3-15/2) downwards. Swing the cover down, remove from the retaining channels on the stand and set aside.

Changing the halogen lamp

- Remove the lamp plug (Fig. 3-16/3) from the halogen lamp (Fig. 3-16/2).
- Press the loops (Fig. 3-16/1) on the securing clips of the lamp holder together and swing them out to the front.
- When changing the lamp, remove the old one (Fig. 3-16/2).
- Position the new lamp with the lower front edge between the contact surface and securing clips.
- Lift the securing clips (Fig. 3-16/1) of the lamp holder with the lamp until they are completely enclosed in the lamp holder. In doing so, slightly press the ends of the securing clips together and guide past the two upper retaining elements. Release the pressure until the clamping bracket opens and engages on both sides in the retaining elements.
- Check that the lamp is seated correctly and push the lamp plug (Fig. 3-16/3) onto the pins of the lamp holder (Fig. 3-16/2). Ensure that it engages properly to avoid bending the pins.
- Insert the cable of the lamp plug into the stand so that it is not damaged when the cover is attached.

Changing the LED illuminator

- Press the loops (Fig. 3-17/1) on the securing clips of the lamp holder together and swing them out to the front.
- Remove the LED illuminator plug (Fig. 3-17/2) from the connector of the stand.
- Pull the old LED illuminator with adapter (Fig. 3-17/3) out of the holding tube (Fig. 3-17/1).

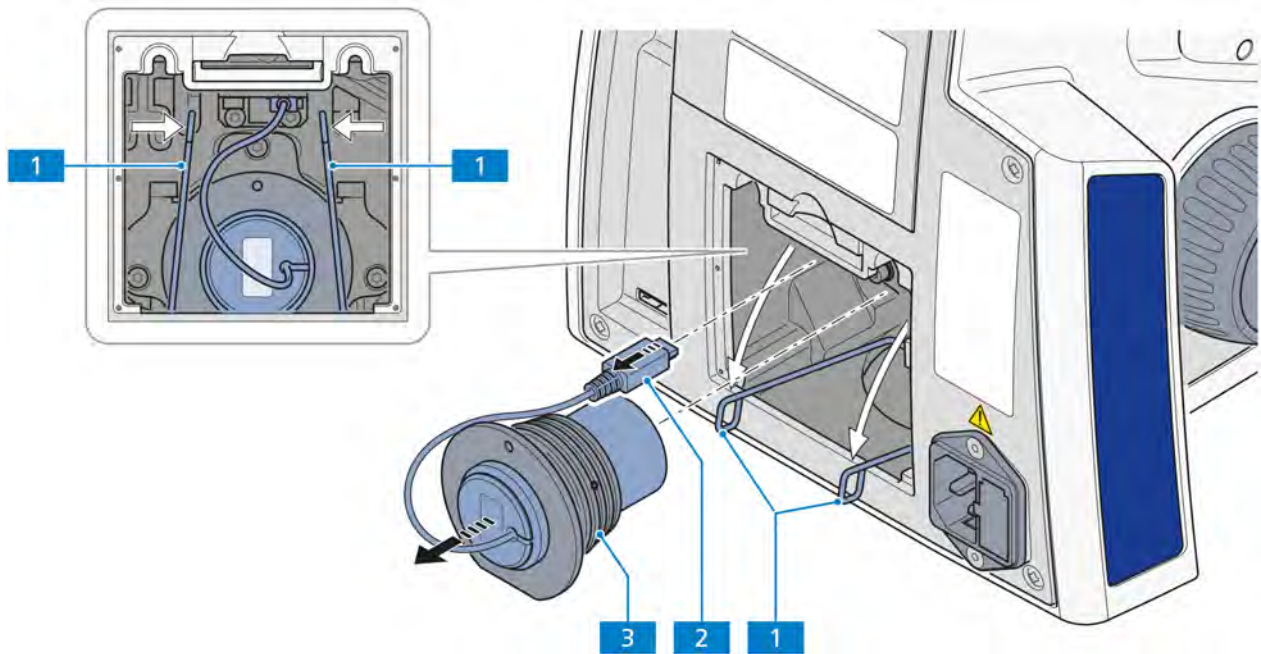

Fig. 3-17 Removing the LED illuminator

- Loosen the three side screws (Fig. 3-18/4a, 4b, 4c) with an Allen wrench (AF 2.5) (Fig. 3-18/3) and remove the old LED illuminator (Fig. 3-18/2) from the adapter (Fig. 3-18/1).
- Insert the new LED illuminator into the adapter and tighten the three side screws on the adapter.

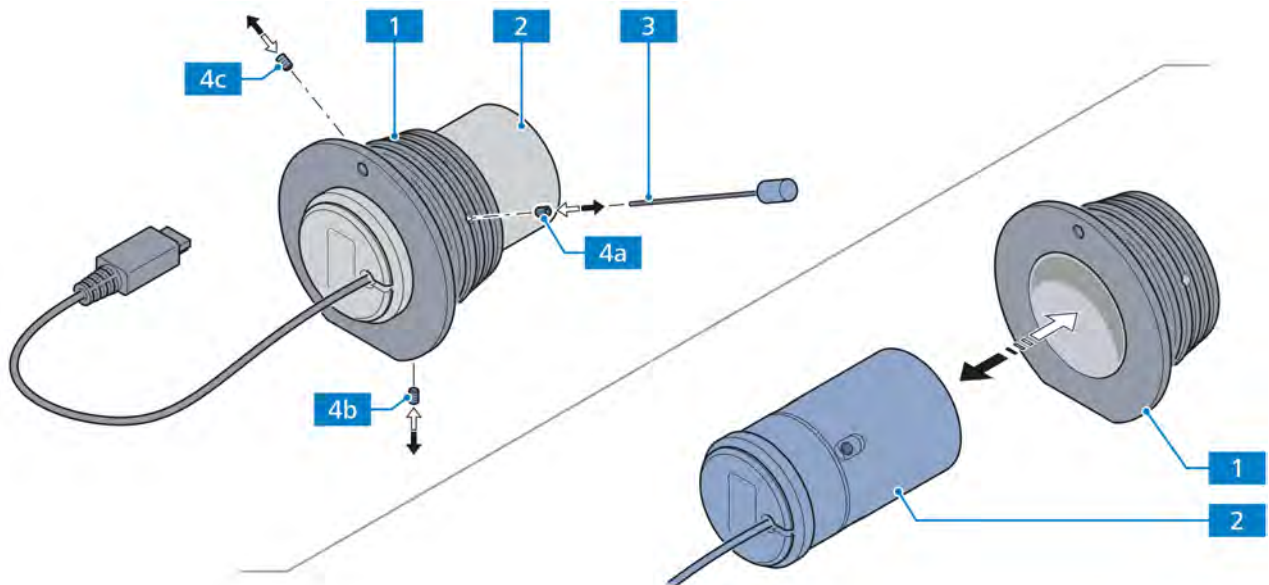

Fig. 3-18 Changing the LED illuminator in the adapter

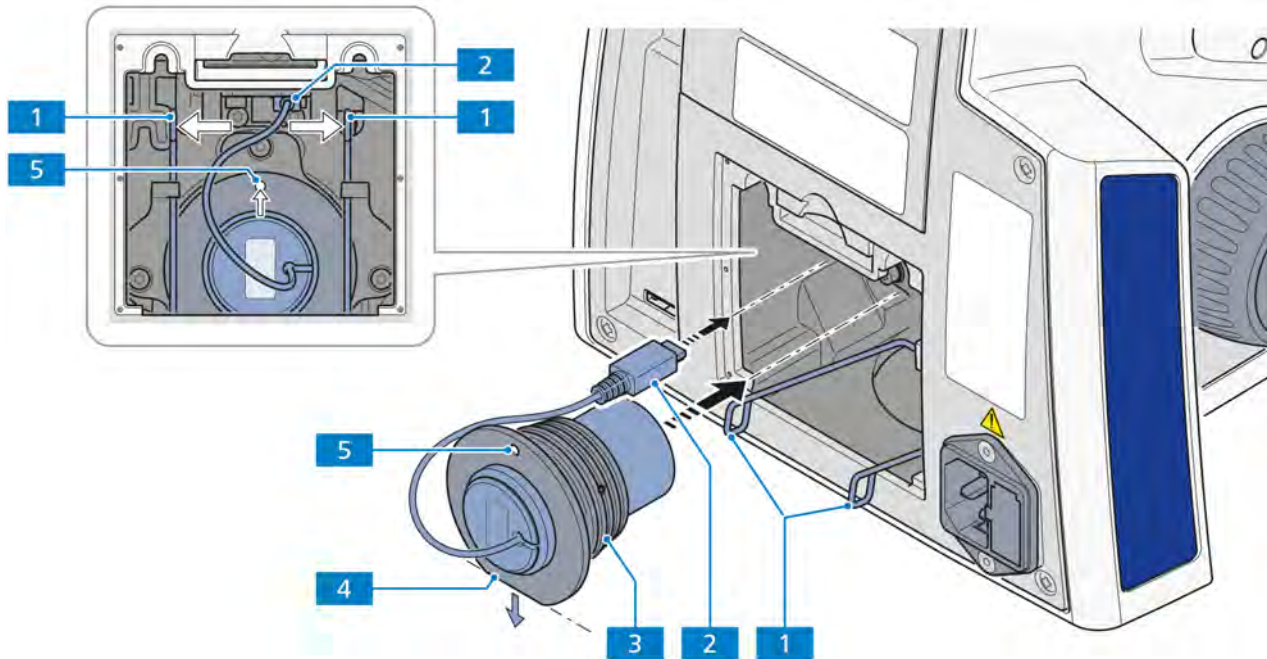

Fig. 3-19 Inserting the LED illuminator

- Insert the new LED illuminator with the adapter (Fig. 3-19/3) into the holding tube up to the stop.
- Position the new LED illuminator with the pinhole (Fig. 3-19/5) at the top, or with the adapter lower front edge (Fig. 3-19/4) aligned between the contact surface and securing clips.
- Plug the illuminator plug (Fig. 3-19/2) into the connector of the stand.
- Lift the securing clips (Fig. 3-19/1) of the lamp holder until they are completely enclosed in the lamp holder. In doing so, slightly press the ends of the securing clips together and guide past the two upper retaining elements. Release the pressure until the clamping bracket opens and engages on both sides in the retaining elements.

Reinserting the cover

- Insert the lower edge of the cover (Fig. 3-15/2) into the retaining channels of the stand and swing upwards until the clamping jaw (Fig. 3-15/1) locks in.
- Reconnect the power cord.

3.1.11 Mounting or replacing the 35 W halogen lamp or the 10 W LED illuminator for reflected light

Axiolab 5 stands are equipped with a 10W LED white light for reflected illumination. The LED illuminator can be alternatively changed to a 35W Halogen lamp.

To insert or replace the halogen lamp/LED illuminator, proceed as follows.

Removing the cover

- Switch off the microscope, remove the power cord on the microscope and allow it to cool down at least 15 min.
- Loosen the screw (Fig. 3-20/1) in the cover.
- Swing the cover (Fig. 3-20/2) slightly upwards and apply pressure from below to remove it from the stand.

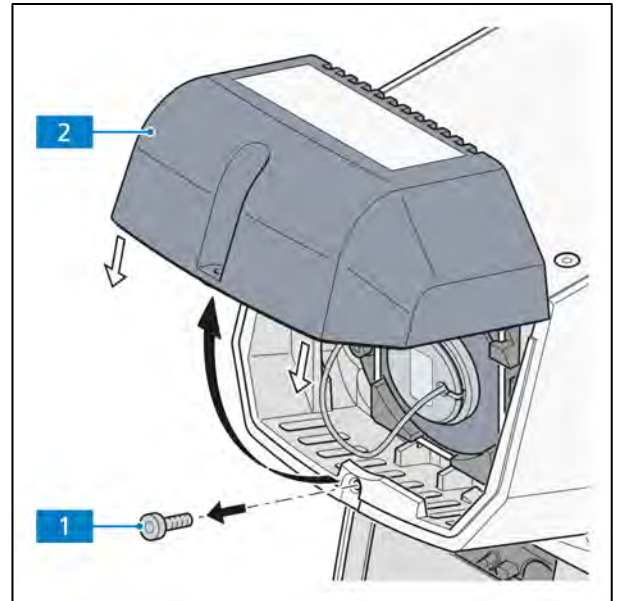

Fig. 3-20 Removing the cover

Changing the halogen lamp

- Remove the lamp plug (Fig. 3-21/3) from the halogen lamp (Fig. 3-21/2).
- Press the loops on the securing clips (Fig. 3-21/1) of the lamp holder together and swing them out to the front.
- When changing the lamp, remove the old one (Fig. 3-21/2).
- Position the new halogen lamp on the contact surface of the lamp holder (the lamp will be held securely by the groove).
- Press the securing clips (Fig. 3-21/1) on both sides of the lamp holder and swing them upwards until the securing clips are seated against the halogen lamp. Slowly release the securing clips so that they open and engage in the retaining elements to the right and left.
- Check that the halogen lamp is correctly seated and push the lamp plug (Fig. 3-21/3) onto the pins of the lamp. Ensure that it engages properly to avoid bending the pins.
- Insert the cable of the lamp plug into the stand so that it is not damaged when the cover is attached.

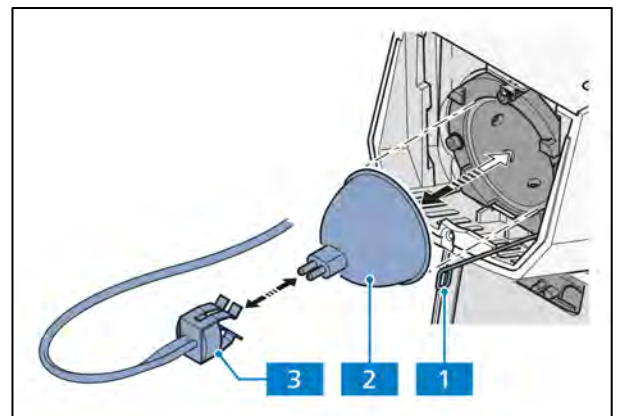

Fig. 3-21 Changing the halogen lamp

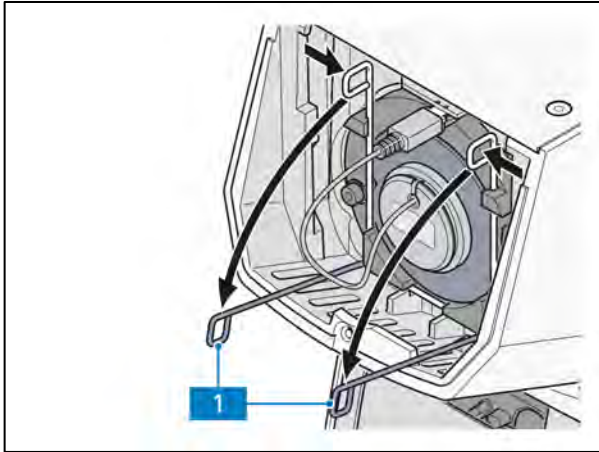

Fig. 3-22 Swinging the loops out

Changing the LED illuminator

- Press the loops (Fig. 3-22/1) on the securing clips of the lamp holder together and swing them out to the front.

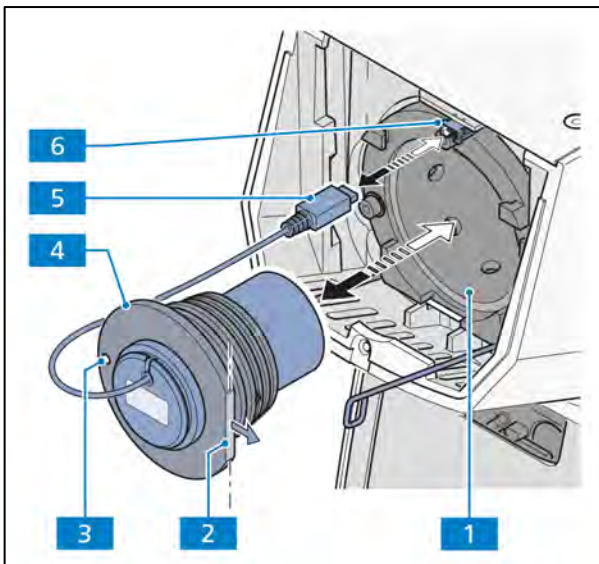

Fig. 3-23 Changing the LED illuminator

- Remove the LED illuminator plug (Fig. 3-23/5) from the connector of the stand (Fig. 3-23/6).
- Pull the old LED illuminator with adapter (Fig. 3-23/4) out of the holding tube (Fig. 3-23/1).

- Loosen the three side screws (Fig. 3-24/4a, 4b, 4c) with an Allen wrench (AF 2.5) (Fig. 3-24/3) and remove the old LED illuminator (Fig. 3-24/2) from the adapter (Fig. 3-24/1).
- Insert the new LED illuminator into the adapter and tighten the three side screws on the adapter.
- Insert the new LED illuminator with adapter (Fig. 3-23/4) into the holding tube (Fig. 3-23/1) up to the stop.
- Position the new LED illuminator with the pinhole (Fig. 3-23/3) at the left, or with the adapter front edge (Fig. 3-23/2) aligned to the right.
- Plug the lamp plug (Fig. 3-23/5) into the connector of the stand (Fig. 3-23/6).
- Lift the securing clips (Fig. 3-22/1) of the lamp holder until they are completely enclosed in the lamp holder. In doing so, slightly press the ends of the securing clips together and guide past the two upper retaining elements. Release the pressure until the clamping bracket opens and engages on both sides in the retaining elements.

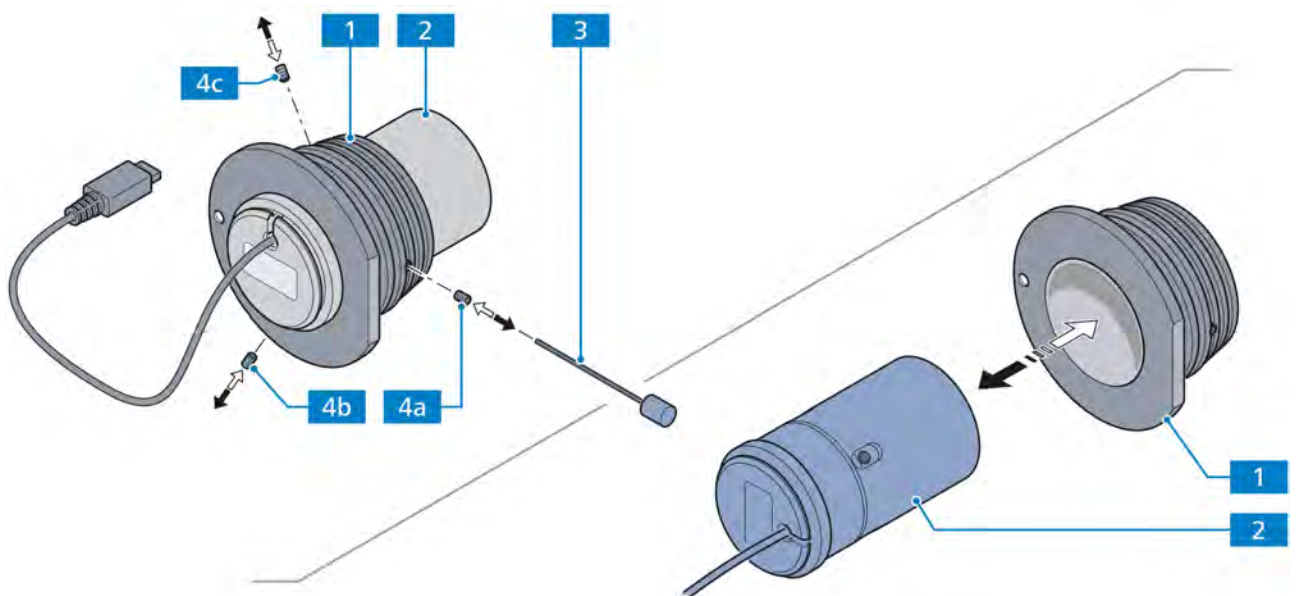

Fig. 3-24 Changing the LED illuminator in the adapter

Reinserting the cover

- Insert the cover (Fig. 3-20/2) at a slant from below into the upper holding elements of the stand, swivel down and press into place.
- Tighten screw (Fig. 3-20/1).
- Reconnect the power cord.

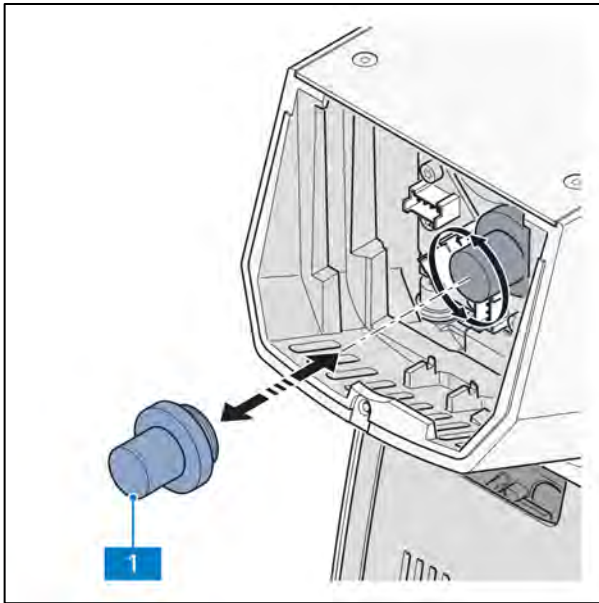

Fig. 3-25 Removing the module holder

3.1.12 Installing or replacing the LED modules for reflected light fluorescence

Axiolab 5 fluorescence stands can accommodate up to three fluorescence LED modules.

To insert or replace the LED modules, proceed as follows.

- Switch off the microscope, remove the power cord on the microscope and allow it to cool down at least 15 min.
- Remove the cover; see also section 3.1.11.
- Unscrew the module holder (Fig. 3-25/1) from the stand socket.
- When changing the modules, remove the module plugs from the connectors (Fig. 3-26/1.2) of the stand.

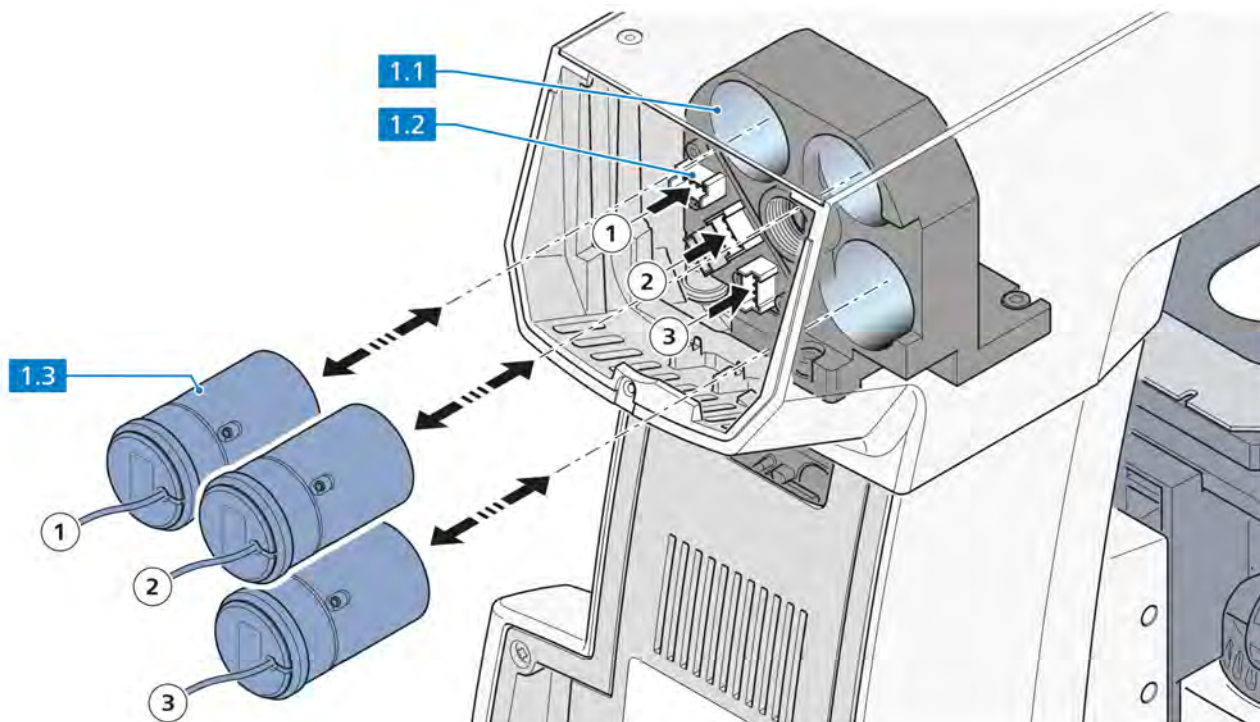



Fig. 3-26 Changing the LED modules

- Pull the old LED modules (Fig. 3-26/1.3) out of the holding positions of the LED tube (Fig. 3-26/1.1).

-
- Insert the new LED modules into the LED tube up to the stop. Ensure that the modules are inserted in the right holding positions (Fig. 3-26/①②③).

	NOTE The LED positions ①, ② and ③ in Fig. 3-26 correspond to the UV , B and G labels on the right side of the microscope (see section 2.4.3, Fig. 2-3/4).
---	--

- Plug the module plugs into the connectors (Fig. 3-26/1.2) of the stand. Ensure that the plugs are connected to the right connectors (Fig. 3-26/①②③).
- Screw the module holder (Fig. 3-26/1) into the LED tube to fix the modules in place.

	NOTE Due to the limited space in the LED module socket, the LED module in position ② needs to be moved out first when replacing the LED module in position ③.
---	---

- Attach the cover; see also section 3.1.11.
- Reconnect the power cord.

3.1.13 Mounting the Axiocam 202 mono or Axiocam 208 color

- Mount the C-mount camera adapter (Fig. 3-27/2) on the Axiocam (Fig. 3-27/1).
- Attach the Axiocam with the adapter to the camera port (Fig. 3-27/4) of the tube.
- Orient the camera to the stand and fix it in position by tightening the ring nut (Fig. 3-27/3).
- Connect the camera to the stand (Fig. 3-27/7) via the USB (Commercial Micro-D) cable (Fig. 3-27/5).
- Connect the camera to an external monitor via an HDMI cable (Fig. 3-27/6).
- Alternatively, connect the camera to a WLAN router or PC.

**NOTE**

Please refer to the microscope operating system modes in section 2.5.10.

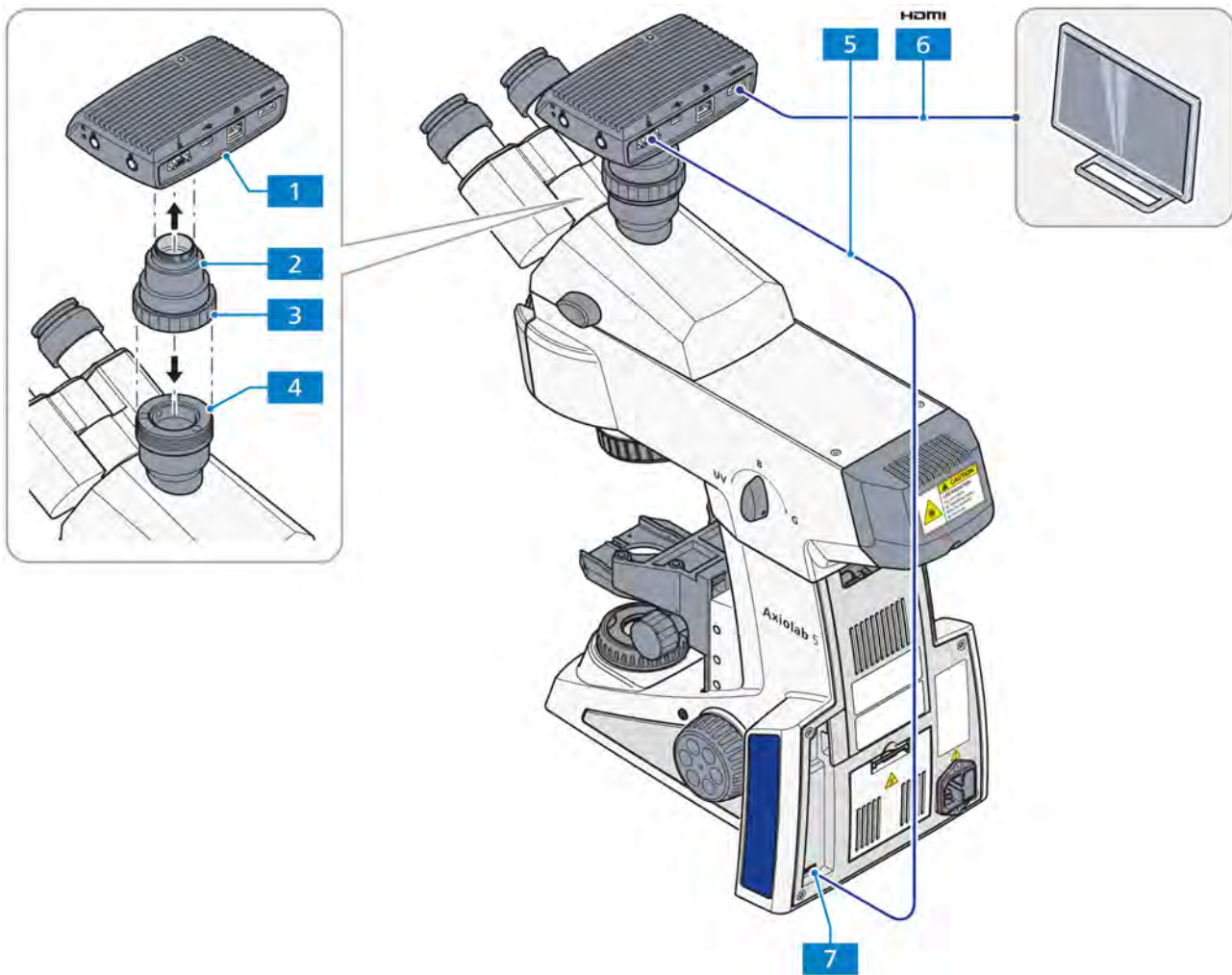

Fig. 3-27 Mounting the Axiocam 202 mono or Axiocam 208 color

3.2 Mounting optional components



CAUTION

The microscope must be switched off and unplugged before starting work.

Upon completion of the work, the function of the respective modules must be restored (see sections 3.1 to 3.4).

3.2.1 Mounting the light intensive co-observer unit

The light-intensive co-observer unit is mounted on the Axiolab 5 with a main observer and one or two co-observers in accordance with the separate instructions for use for multi-conference facilities (order no. 425145-7144-001).

3.2.2 Mounting polarizer D or filter holder

- Lift the condenser carrier together with its knurled knob upwards as far as it will go.
- If necessary, unscrew the locking and holding pins together with the low-power system from the condenser carrier.
- Hold the polarizer or filter holder (Fig. 3-28/4) parallel to the underside of the condenser carrier (Fig. 3-28/1) and screw the holding pin (Fig. 3-28/2) of the polarizer (Fig. 3-28/4) with the angled adjusting lever (Fig. 3-28/3) into the front left threaded hole below the condenser carrier as far as it will go.
- Screw the locking pin (Fig. 3-28/6) with the adjusting lever (Fig. 3-28/5) as far as it will go into the rear threaded hole of the condenser carrier.

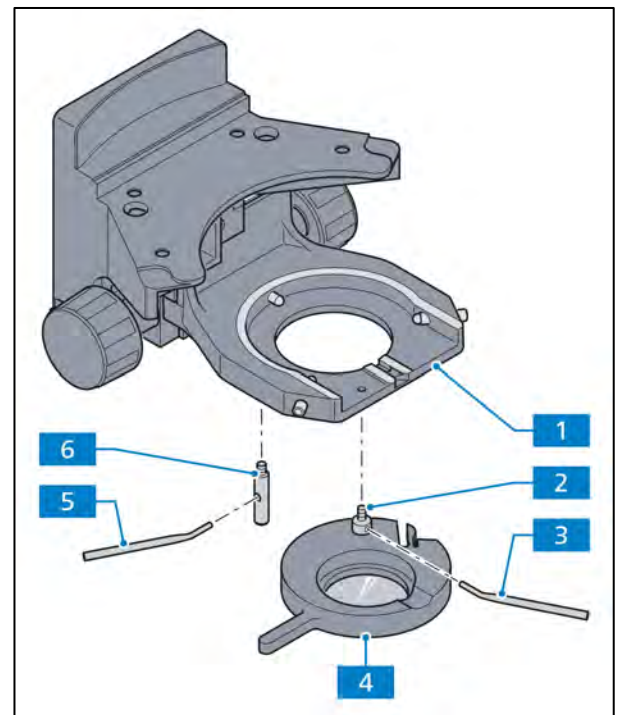

Fig. 3-28 Mounting the polarizer D

The other components shown in the system overview at this point must be mounted in a similar manner.

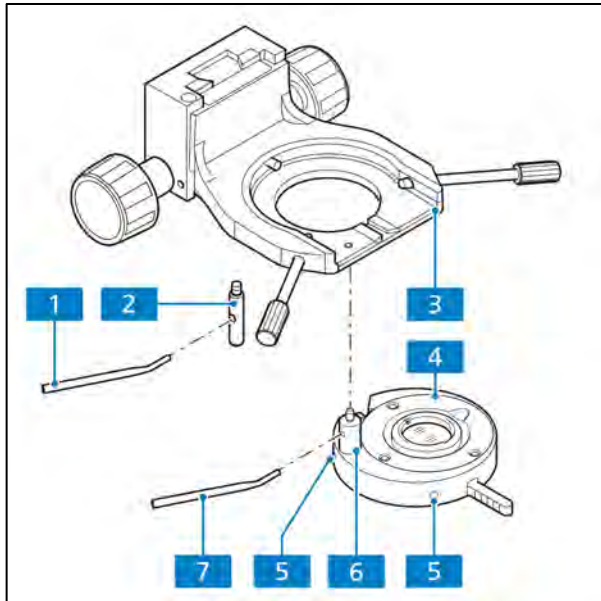

Fig. 3-29 Mounting the low-power system

3.2.3 Mounting and centering the low-power system for the objectives 2.5x/4x

- If necessary, remove the polarizer or filter holder from the condenser carrier.
 - Hold the low-power system (Fig. 3-29/4) parallel to the bottom of the condenser carrier (Fig. 3-29/3) and screw the bracket bolt (Fig. 3-29/6) of the low-power system with the angled adjustment lever (Fig. 3-29/7) into the front threaded opening to the left below the condenser carrier (Fig. 3-29/3) until it stops.
 - With the adjustment lever (Fig. 3-29/1), screw the stop bolt (Fig. 3-29/2) into the back threaded opening of the condenser barrier (Fig. 3-29/3) to the stop.
 - Swing the low-power system into the beam path. Make sure that the fixture is securely engaged.
- Open the aperture diaphragm and field diaphragm completely.
 - Adjust both adjustment screws (Fig. 3-29/5) using two Allen wrenches (AF 1.5) until the field of vision is optimally illuminated.



NOTE

The low-power system can be used only in combination with the condenser 0.9/1.25.

3.2.4 Inserting the modulator disk in the condenser 0.9 BF Pol

- Remove the condenser (Fig. 3-30/1) from the condenser carrier (see section 3.1.8).
If the condenser cannot be lowered sufficiently, e.g. with the low-power system mounted, then it may be necessary to remove it with the stage carrier, then lower it to the stop and remove the condenser.
- Loosen the clamping screw (Fig. 3-30/5) of the condenser's dial segment (Fig. 3-30/3) with the Allen wrench (AF 3) and pull out the dial segment.
- Slide the modulator disk (Fig. 3-30/4) with its two-pronged forked opening pointing forward into the condenser. Make sure that the disk engages in the guide on both inner sides of the condenser. The guide serves as a stop for the modulator disk. The pin of the disk's clamping screw must slide into the orientation groove of the condenser.
- Tighten the disk's clamping screw with the Allen wrench (AF 3).
- Replace the condenser in its carrier (see section 3.1.8).

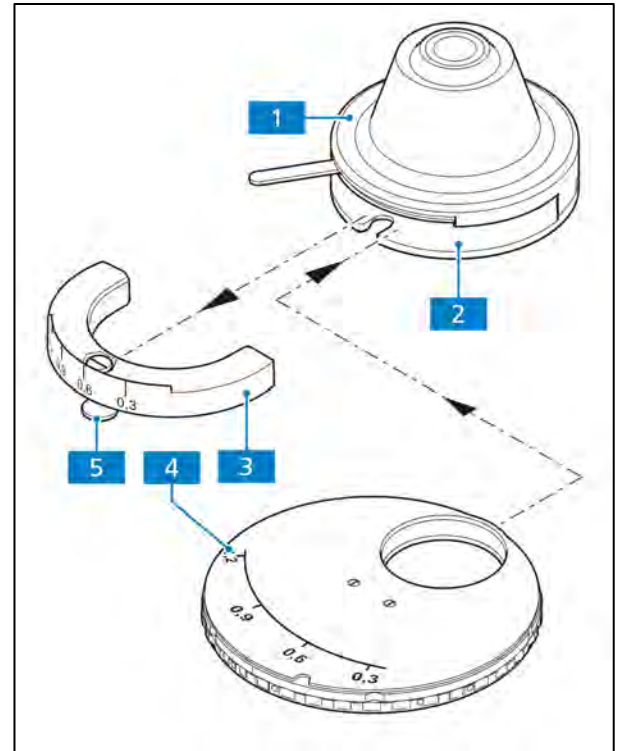

Fig. 3-30 Modulator disk in condenser 0.9 H Pol

3.3 Connecting to the power supply

The power supply of the Axiolab 5 is located at the back of the instrument in all stand models.

- Connect the microscope (Fig. 3-31/1) to the power supply via a power cord and mains socket.
- The Axiolab 5 can be connected to a line voltage ranging from 100 to 240 VAC, with frequencies of 50/60 Hz. The power unit is set **automatically** to the line voltage available.

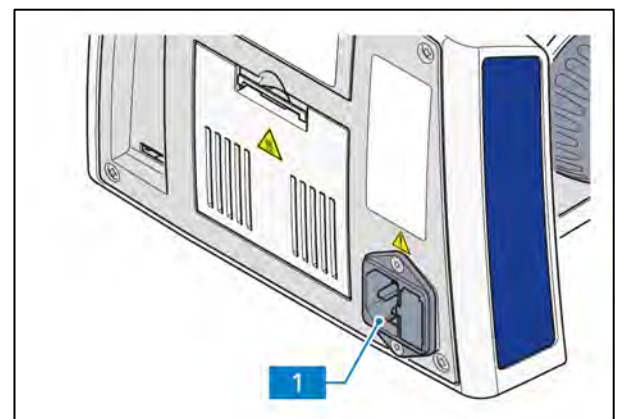

Fig. 3-31 Power supply connector on the back of the stand

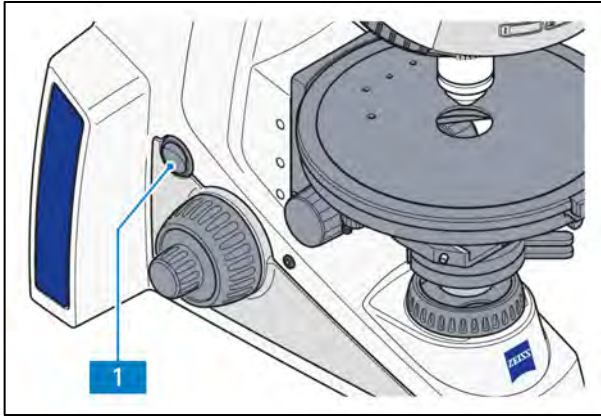

Fig. 3-32 Mains switch on left side of microscope

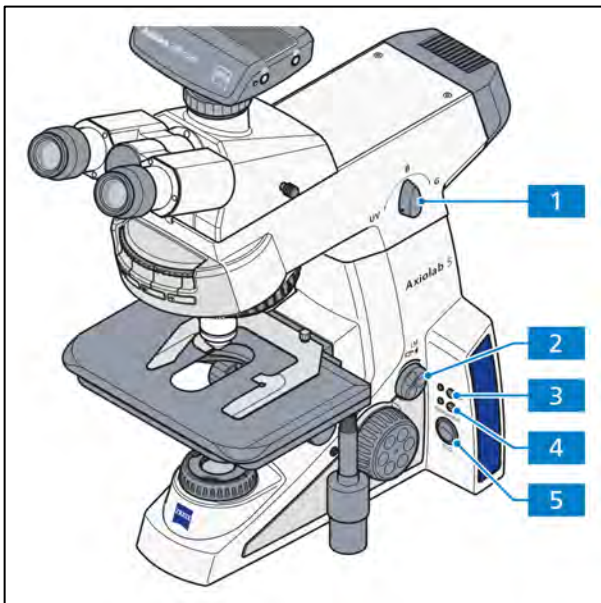

Fig. 3-33 Intensity/LM knob and illumination modes

3.4 Switching the microscope on/off

- Switch the microscope on/off using (Fig. 3-32/1) the on/off switch.
- If available, select the transmitted or reflected light illuminator by pushing the **TL** (Fig. 3-33/4) or **RL** (Fig. 3-33/3) button.

The respective indicator light is continuously illuminated in green.

- Adjust image brightness using the **Intensity/LM** knob (Fig. 3-33/2). To do this, take hold of the recessed grips of the knob with your fingertips and turn it to the desired position.

Pressing the **Intensity/LM** knob initiates further functionality, see sections 2.4.8 and 3.5.

- Select **Permanent** or **ECO** mode (Fig. 3-33/5) for using the microscope illumination.

If **Permanent** mode is active: The illumination is continuously switched on.

If **ECO** mode is active: The illumination switches off after 15 minutes without action.

Only Axiolab 5 stand, Bio-TL/FL:

- Select the desired LED for fluorescence application using the LED selection knob (Fig. 3-33/1).

3.5 Using the Light Manager function

The Light Manager (LM) function saves the ratios of the set light intensities between different combinations of objective and reflector turret positions for a given light source. When changing the light intensity of one objective/reflector combination, the light intensities of other combinations will also change according to the set ratios. This ensures that users don't need to repeatedly set up light intensities for each objective/reflector combination when switching between samples which require different illumination intensity.

After switching on the microscope, the previous setting of the Light Manager will be restored.

Disable/enable the LM function

To disable the LM function, proceed as follows:

- Press one of the **Snap** buttons **and** the **Intensity/LM** knob simultaneously for at least 1.5 seconds.

The indicator light blinks in the following sequence: GREEN / ORANGE / GREEN

To enable the LM function, proceed as follows:

- Press one of the **Snap** buttons **and** the **Intensity/LM** knob simultaneously for at least 1.5 seconds.

The indicator light blinks in the following sequence: GREEN / GREEN / GREEN

Save light intensity ratios using the LM function

1. Switch to the first objective and/or reflector positions of interest.
2. Set the desired light intensity.
3. Press the Intensity/LM knob for at least 1.5 seconds.
4. The light intensity for this objective/reflector combination is then saved. When using LED as light source, after the light intensity is saved, LED is switched off for 300 ms. This is visible through eyepieces and serves as an indicator for the user.
5. Proceed by switching to the second objective/reflector combination, and press the Intensity/LM knob for at least 1.5 seconds. Now a ratio between the first and the second objective/reflector combinations is established.
6. Repeat step 5 to set light intensity ratios for more objective/reflector combinations.

3.6 Default factory settings of the microscope

The default factory settings are:

- Light Manager enabled, but no light intensity values saved
- Light intensity set to initial minimum value
- all configuration stored will be cleared

To reset the microscope to default factory settings, proceed as follows:

- Press and hold down the **Intensity/LM** knob for 20 seconds.

While the knob is held down from 3 s to 20 s, the indicator light blinks RED.

It blinks GREEN after 20 s are reached. When the indicator stops blinking and remains GREEN, the reset to the default factory setting is successful.



ATTENTION

Please use this function with caution as it will reset **all** existing configurations.

4 OPERATION

4.1 Default setting of the microscope

4.1.1 Setting the inter-pupillary distance on the binocular tube

- Adjust the individual inter-pupillary distance by symmetrically swiveling the two eyepiece tubes towards each other (Fig. 4-1).

The correct inter-pupillary distance has been set when the observer sees only **one** round image when looking into the eyepieces.

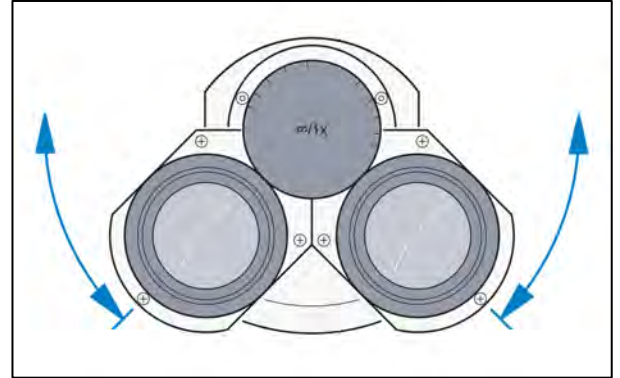

Fig. 4-1 Setting the inter-pupillary distance on the binocular tube

4.1.2 Setting the viewing height

- Adjust the viewing height to your individual requirements by swiveling the eyepiece tubes up (Fig. 4-2/A) or down (Fig. 4-2/B).

This individual height adjustment in two stages (upper and lower position) is basically possible with all tubes of the Axiolab 5 program. The viewing height thus achieved depends on the selected inter-pupillary distance and the tube viewing angle, which may be stationary or variable, depending on the model. With an inter-pupillary distance of 65 mm and a tube viewing angle of 30°, the height adjustment range is approximately 40 mm.

Binocular ergo (photo) tubes (425511-0000-000, 425512-0000-000, 425514-0000-000, 425520-9050-000) are provided with continuous vertical adjustment with a range of 44 mm to 50 mm.

The binocular part of the ergo photo tube 425520-9050-000 is also continuously horizontally retractable up to 50 mm.

The eyepoint angle of the binocular ergo (photo) tubes (425522-9020-000 and 425522-9030-000) is continuously adjustable within a range from 8° to 38°.

The comfortable binocular ergo tube (425522-9040-000) is continuously height-adjustable by up to 50 mm and angle-adjustable from 8° to 33°. This is the ergo tube which received the highest rating and recommendation from TÜV in terms of microscope workstation ergonomics.

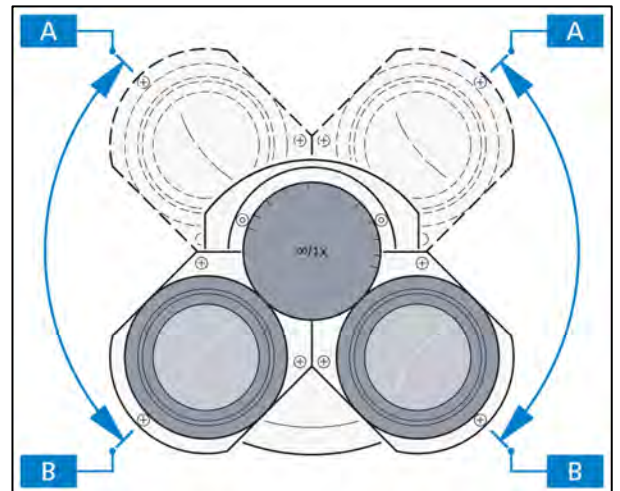

Fig. 4-2 Setting the viewing height on the binocular tube

4.1.3 Adjusting for ametropia (user's visual impairment) when using eyepiece reticles

The prerequisite for correct use of an eyepiece reticle is two adjustable eyepieces to compensate for different degrees of ametropia of the user.

- Focus on the line figure of the eyepiece reticle with the focusable eye lens of the adjustable eyepiece.
- Focus on the microscopic image of a loaded specimen with the focusing drive while observing with the eyepiece containing the eyepiece reticle.
- When both the microscopic image and the eyepiece reticle are in focus, the image for the second eye is brought into focus with the focusable eye lens of the second eyepiece.

Both microscopic images including the eyepiece reticle are thus in focus. From this point, use only the focusing drive for any subsequent focusing activity.

4.2 Illumination and contrast methods in transmitted light

4.2.1 Configuring transmitted light brightfield microscopy using the KÖHLER method

(1) General principle of operation

Transmitted light brightfield microscopy is the most commonly used method of optical microscopy. High-contrast or tinted (stained) samples (e.g. a blood smear) can be examined easily and quickly.

For an imaging result which is as true to the specimen as possible, we must consider the so-called direct bundled beams as well as the indirect ones, i.e. the beams which diffract and scatter on the sample details. According to ABBE, the image is truer to the specimen when the fraction of the cone of light is as large as possible.

The best performance of the microscope, and especially its objective, is achieved when the condenser, field diaphragm and aperture diaphragm are adjusted using the KÖHLER illumination method. These basic rules for adjusting a microscope are explained in detail in section 4.2.1 (3) "Configuring transmitted light brightfield microscopy using the KÖHLER method".

(2) Instrumentation for transmitted light brightfield microscopy

The equipment of every Axiolab 5 microscope, except the stand for reflected light, permits the use of transmitted light brightfield microscopy.

All available condensers, except special condensers such as darkfield condensers, can be used for transmitted light brightfield microscopy.

(3) Configuring transmitted light brightfield microscopy using the KÖHLER method

- The Axiolab 5 has been started up correctly (see section 3).
- The Axiolab 5 is switched on.
- Adjust the image brightness using the Intensity/LM knob (Fig. 4-3/1) on the microscope stand.
- Insert a high-contrast specimen into the specimen holder of the mechanical stage.
- If condensers with a swiveling front lens are used, swivel these into the beam path with $\geq 10\times$ objectives and set the condenser with the knurled knob for vertical adjustment (Fig. 4-3/3 or Fig. 4-4/2) to the upper stop. The stop must be adjusted so that the specimen is not lifted by the condenser (to set the condenser stop, see section 4.2.1 (4)).
- When using condensers with a turret/modulator disk and knurled ring (Fig. 4-4/3), set position **B** (or **H** = brightfield).
- Swivel in the 10x objective on the nosepiece (Fig. 4-3/6) and use the focus drive to focus on the specimen (Fig. 4-3/2).

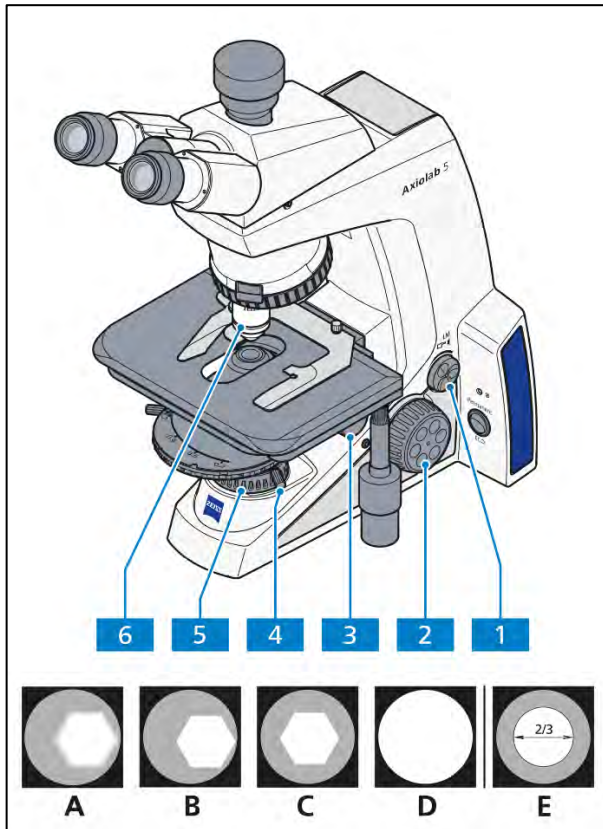

Fig. 4-3 Microscope settings in transmitted light brightfield microscopy

- Close the luminous-field diaphragm (Fig. 4-3/5) until it is visible (even if not in focus) in the field of view (Fig. 4-3/A).
- Turn the vertical control of the condenser drive to lower the condenser until the edge of the luminous-field diaphragm appears in focus (Fig. 4-3/B).
- Center the luminous-field diaphragm using the two centering screws (Fig. 4-3/4) on the condenser carrier (Fig. 4-3/C) and then open the luminous-field diaphragm until the edge of the diaphragm just disappears from the field of vision (Fig. 4-3/D).
- To adjust the aperture diaphragm (contrast), remove an eyepiece from the eyepiece tube and look into the tube with the naked eye. Set the aperture diaphragm with the adjusting lever (Fig. 4-4/4) to between $2/3$ - $4/5$ of the diameter of the exit pupil of the objective (Fig. 4-3/E). In most applications, this aperture diaphragm setting provides optimal contrast at almost ideal resolution, and is therefore the best compromise for the human eye.
- Reinsert the eyepiece into the eyepiece tube.



NOTE

Every change of objective will result in a change in specimen field size and objective aperture, together with a possible slight change in centering, so that for optimal results the luminous-field and aperture diaphragm adjustments must be repeated.

With objectives $< 10x$, the front lens of the condenser (if swivelable) must be swiveled out of the beam path and the aperture diaphragm completely opened. For better contrast with such large object fields, the luminous-field aperture should be closed to a certain extent. Overclosing should be avoided so as not to impair the uniformity of the illumination of the field of view.

(4) Setting the height stop on the condenser carrier

- Loosen the fastening screw (Fig. 4-4/1) of the height stop using an Allen wrench (AF 3).
- Use the focusing drive to focus on the specimen.
- Close the luminous-field diaphragm and focus it by turning the vertical control (Fig. 4-4/2) of the condenser.
- Carefully raise the condenser slightly without lifting the specimen.
- Tighten the fastening screw (Fig. 4-4/1) of the height stop.

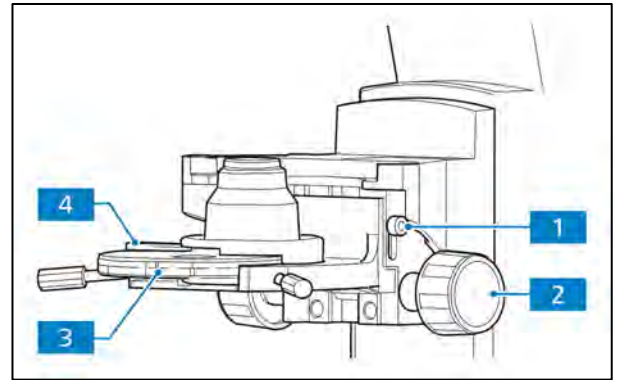

Fig. 4-4 Setting the height stop on the condenser carrier

4.2.2 Configuring transmitted light darkfield microscopy using the KÖHLER method

(1) General principle

Due to their transparency, unstained biological specimens, such as bacteria or living cell cultures, are often barely or not at all visible in transmitted light brightfield microscopy. This is radically changed when such specimens are observed in transmitted light darkfield microscopy. In principle, the specimen is exposed to light from an illumination aperture which is larger than that of the objective used.

In darkfield microscopy, only the diffracted and scattered light components which are important for imaging reach the objective, while the direct unchanged light bundles are routed past the objective. This is one of the reasons why even fine structures that are sometimes below the resolving power of the light microscope can be resolved and appear very bright on a dark background.

(2) Instrumentation

All Axiolab 5 microscopes, except stands for reflected light, are suitable for darkfield applications.

Condenser with darkfield stop in position **D** e.g.:

- Condenser 0.9/1.25 H with modulator disk BF, DF, Ph 1, Ph 2, Ph 3
- Condenser, achrom.-aplan. 0.9 H D Ph DIC
- Darkfield condenser with dry darkfield (465505-0000-000 applicable aperture from 0.6 – 0.75)
- Ultra condenser (465500-0000-000 applicable aperture from 0.75 – 1)

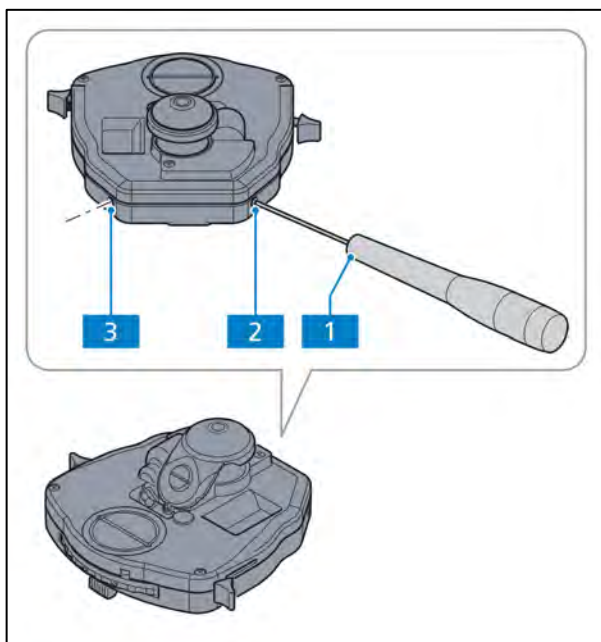

Fig. 4-5 Centering the darkfield stop on condenser, achromatic-aplanatic 0.9 H D Ph DIC

(3) Configuring transmitted light darkfield microscopy

- Adjust the brightness using the KÖHLER method as for transmitted light brightfield microscopy. Instead of the 10x objective, however, swivel in the objective with the highest aperture which does not exceed the limit aperture for the darkfield with the condenser used.
 - Position the turret/modulator disk of the condenser at **D** and swivel in the condenser front lens (if existing).
 - Remove the eyepiece from the tube (or replace it with an auxiliary microscope) and check the centering of the darkfield diaphragm in the exit pupil of the objective. If the central darkfield stop **D** in the universal condenser is partly outside of or de-centered to the exit pupil of the objective, and if the exit pupil is not homogeneously dark, the darkfield stop must be re-centered.
- To center the darkfield stop (not possible with all condensers), use two Allen wrenches (AF 1.5) (Fig. 4-5/1) to turn the two centering screws (Fig. 4-5/2 and 3) until the exit pupil of the objective appears homogeneously dark. After centering, remove both Allen wrenches (AF 1.5) from the condenser.

**NOTE**

Since the apertures of objectives with an integrated aperture iris stop are too high for transmitted light darkfield microscopy, the aperture iris stop must at least be closed to the limit aperture of 0.65.

The performance criterion for the darkfield method is always the darkest possible background of the field of view.

- Reinsert the eyepiece into the tube.
- If the height of the darkfield condenser is set correctly and sensitively, it is possible to reduce any brightening in the field of view left, and the luminous-field diaphragm image appears almost perfectly in focus.
- Finally, match the size of the luminous-field diaphragm to the size of the field of view.

Darkfield microscopy requires specimens to be considerably cleaner than in other techniques. In particular, fingerprints, dirt or dust particles have a negative effect, as they brighten the background of the field of view and decrease the contrast of the object image.

(4) Setting darkfield contrast with a dry darkfield condenser

- If necessary, swivel out the low-power system, polarizer or λ plate.
- Move the condenser carrier down until the end stop.
- Place the dry darkfield condenser in the condenser holder Z (see section 3.1.9).
- Place the condenser holder Z in the condenser carrier and center it roughly, so the condenser fits into the opening of the mechanical stage without contact when moving upwards.
- Move the condenser up to the end stop. Position the specimen and adjust the illumination intensity so that it is bright enough.
- Swivel in a low-magnification objective (e.g. 5x or 10x) and focus on the specimen, using the focusing drive.
- Position a specimen so that its details are distributed evenly in the field of view. This will make the image of the field diaphragm easier to identify.
- Close the field diaphragm down to the end stop.
- Lower the condenser until the edge of the field diaphragm appears sharp (luminous-field diaphragm focus level). There will be an increasing or decreasing light ring visible when the focus is moved upwards or downwards from the field diaphragm focus level (so-called circular "breathing" of the field diaphragm depiction).
- Center the field diaphragm image with both centering screws on the condenser carrier.
- Swivel in the desired objective.
- Focus the specimen with the focusing drive, if necessary.
- Focus the field diaphragm using the condenser drive. Open the field diaphragm enough to make the edge of the diaphragm disappear from the field of view.
- Optimize the contrast with the aperture diaphragm of the condenser, if necessary.

(5) Setting darkfield contrast with the immersion oil darkfield condenser

- If necessary, swivel out the low-power system, polarizer or λ plate.
- Move the condenser carrier down until the end stop.
- Place the immersion oil darkfield condenser in the condenser holder Z (see section 3.1.9).
- Place the condenser holder Z in the condenser carrier and center it roughly, so the condenser fits into the opening of the mechanical stage without contact when moving upwards.
- Move the condenser up to the end stop.
- Place a drop of immersion oil (without bubbles, if possible) on the center of the condenser.
- Position a specimen. The immersion oil will disperse between the condenser and specimen holder.
- Move the mechanical stage back and forth slightly to dissipate any air bubbles in the immersion oil.
- Adjust the illumination intensity so that it is bright enough and open the field diaphragm completely.
- Swivel in a low-magnification objective (e.g. 10x) and focus the specimen, using the focusing drive.
- Center the field diaphragm on the condenser carrier with the adjustment screws and focus the image with the condenser drive.
- Place a drop of immersion oil on the specimen holder, swivel in the immersion oil objective and focus the specimen.
- Close the field diaphragm down to the end stop.
- Lower the condenser until the edge of the field diaphragm appears sharp.
- Center the field diaphragm image with both centering screws on the condenser carrier.

The luminous field diaphragm appears only as a circle segment on the edge of the viewing field due to the high magnification of the immersion oil objective. As a result, the focusing and centering of the field diaphragm must be repeated. If necessary, the luminous-field objective should be opened slightly if the light intensity is too low.

The field diaphragm is centered properly when the edge of the luminous field diaphragm is centered or equidistant from the edges of the viewing field.

- For a sharply focused specimen, open the sharply set field diaphragm enough to make the edge of the diaphragm disappear from the field of view.
- You can improve the contrast of the microscope image by slightly adjusting the focus level of the condenser with the condenser drive.
- The background of the eyepiece image should appear evenly dark.
- For immersion oil objectives with an iris diaphragm, the contrast can be further optimized by turning the adjustment wheel of the iris diaphragm.

4.2.3 Configuring transmitted light phase contrast microscopy

(1) General principle

The phase contrast technique is ideal for examining thin, unstained specimens such as cultured cells. Generally, the human eye is unable to perceive phase differences (index and thickness differences) between the different cell components.

The phase contrast technique uses "phase stop and phase ring" optical modulators and interference procedures in forming the intermediate image in order to transform small phase differences into differences in intensity and color which are visible to the human eye.

High-intensity, direct light components are attenuated with the optically defined ring channel "phase stop and phase ring" and given a constant phase shift. However, the indirect light components diffracted at different cell components bypass this optical channel and are influenced in phase by the refractive index and the thickness differences in the specimen.

Interference in the intermediate image level occurs due to the differently influenced partial beams, and these strengthen or weaken according to phase position. This interference results mainly in image contents displaying differences in intensity which can be perceived by the human eye.

(2) Instrumentation

All Axiolab 5 microscopes, except stands for reflected light, are suitable for phase contrast applications.

- Phase contrast objectives with phase rings Ph 1, Ph 2 or Ph 3 for different average numerical apertures which can also be used in the brightfield.
- Condenser with turret/modulator disk containing centering phase stops Ph 1, Ph 2 and Ph 3 for different average numerical apertures.
- The phase stop used on the condenser must correspond to the label on the objective used, e.g. Ph 1.

(3) Configuring transmitted light phase contrast microscopy

- Swivel the phase contrast objective, e.g. labeled **Ph 1**, into the beam path.
- Switch on the annular phase diaphragm on the condenser's revolver disk which has the same label as the phase contrast objective, e.g. 1.
- In order to check the centering and the overlap of the lighter annular diaphragm (in the condenser) with the darker phase ring (in the objective), remove an eyepiece from the tube and replace it with an auxiliary microscope. Use the adjusting fixture on the auxiliary microscope to focus the annular diaphragm and the phase ring in the objective exit pupil.

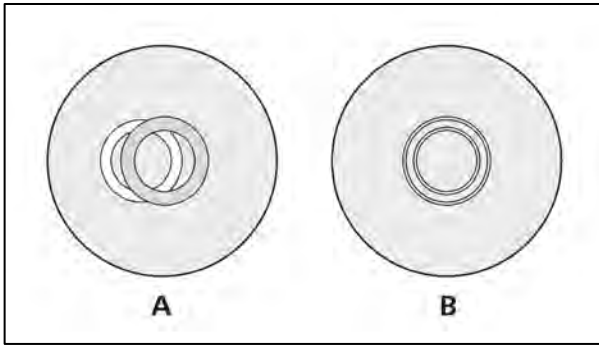

Fig. 4-6 Centering the annular phase diaphragm (light-colored, in the condenser) and the phase ring (dark-colored, in the object)

- If the overlap is not exact (Fig. 4-6/**A**), the lighter annular diaphragm must be recentered with the aid of two Allen wrenches (AF 1.5) (Fig. 4-5/**1** and **4**). Adjust the two centering screws (Fig. 4-5/**2** and **3**) so that you achieve a full overlap with the darker phase ring (Fig. 4-6/**B**).
- Remove the auxiliary microscope from the tube and replace it with the eyepiece.

In order to increase the image contrast, an interference broadband filter, green 32 x 4, may be mounted on the field diaphragm or inserted into the color glass carrier (if available).

A complete phase contrast can only be achieved when the light-colored annular diaphragm (in the condenser) overlaps exactly with the dark-colored phase ring (in the objective) in the illumination beam path (Fig. 4-6/**B**).

4.2.4 Configuring transmitted light polarization microscopy

4.2.4.1 Detecting birefringence

(1) Application

The transmitted light polarization method is used for samples which change the polarization of the light. Such samples are called birefringent. Examples include crystals, minerals or polymers. If such birefringent substances are observed between crossed polarizers, the birefringent portion of the sample appears bright while its surroundings remain dark.

A birefringent substance can be recognized by rotating the sample by 360° between crossed polarizers. The sample should show four bright and four dark appearances during the rotation procedure. During the rotation procedure, interference colors appear that range from gray (mostly for biological samples) through white, yellow and red to blue, depending on the birefringence, thickness and orientation of the sample. The interference colors may be of the first or a higher order.

(2) Instrumentation

Polarization methods can be used in the transmitted light on Axiolab 5 microscopes for transmitted light polarization and conoscopy.

- Strain-free objectives
- Pol rotary stage
- Polarizer D (rotatable or fixed)
- Analyzer slider D, fixed, or lambda compensator or lambda/4 compensator
- Depolarizer (for screwing into Axiolab 5 tubes) to avoid undesirable polarization effects



NOTE

The depolarizer is already incorporated in the Axiolab 5 stand for conoscopy.

A depolarizer (quartz depolarizer) should be incorporated in all microscopes used to examine mineralogical/geological specimens.

A depolarizer extinguishes undesirable polarization effects (e.g. false or pseudo-pleochroism) that may occur behind the analyzer (e.g. on prism surfaces in the tube), or shifts them to higher orders.

(3) Configuring the microscope

- Configure the microscope as for transmitted light brightfield microscopy using the KÖHLER method (see section 4.2.1 (3)).
- Center the Pol rotary stage (Fig. 4-7/1) (see section 3.1.7.5) and objectives (see section 3.1.7.6).
- Swing the polarizer (Fig. 4-7/3) into the beam path and position it to 0° if you are using a rotatable polarizer.
- Insert the analyzer slider (Fig. 4-7/2) into the slot for compensators (if the tube does not already have an analyzer). The field of view will appear dark due to the crossed polarizers. With screw-on analyzers in the intermediate plate for tubes, care must be taken to ensure that they are aligned with polarizer D (i.e. crossed position).
- Bring the specimen to be examined into the field of view and turn it with the rotary stage. Normally, birefringent (anisotropic) objects will now show the interference color and intensity variations as described above during rotation between crossed polarizers. Optically anisotropic substances may remain dark when an isotropic direction, e.g. from optically single-axle or double-axle crystals, is oriented parallel to the observation direction.

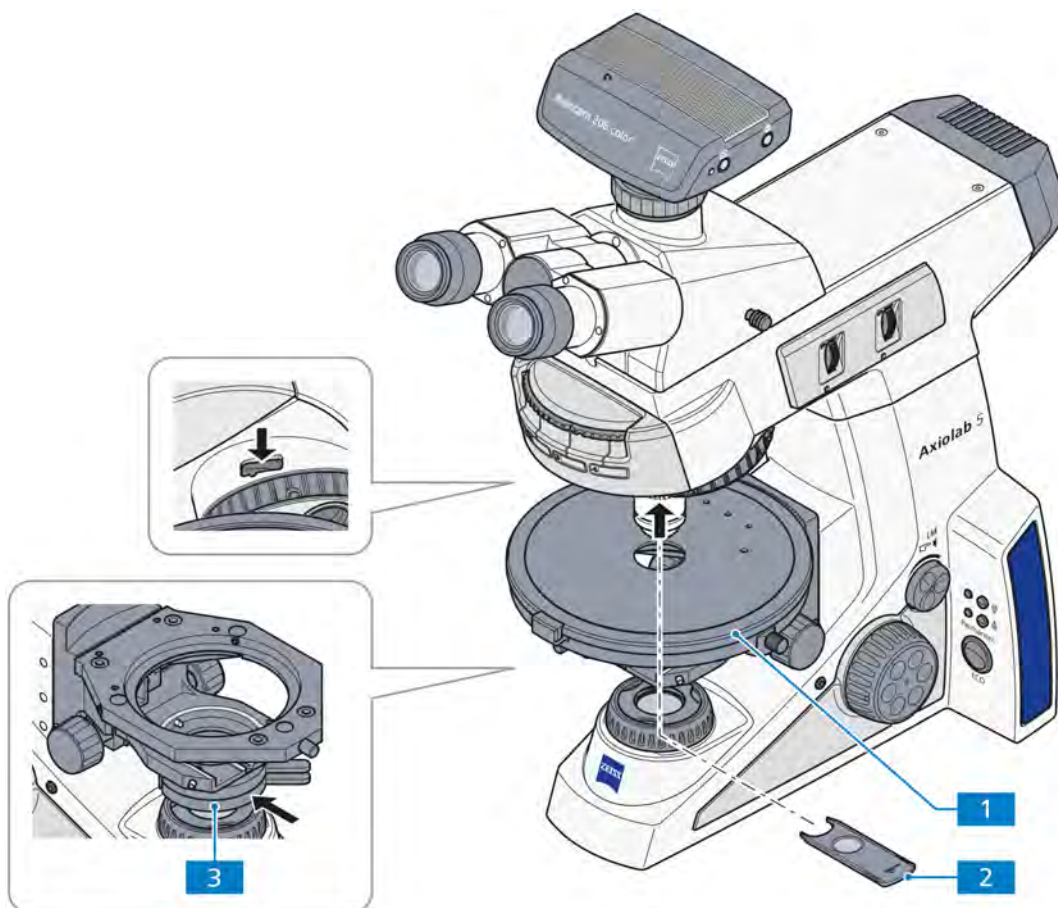

Fig. 4-7 Components for transmitted light polarization

4.2.4.2 Determination of the polarization direction n_{γ}

(1) Application

The determination of the polarization direction of n_{γ} or $n_{\gamma'}$ respectively (polarization direction with the absolute or relative largest index of refraction) and n_{α} or $n_{\alpha'}$ respectively (polarization direction with the absolute or relative smallest index of refraction) relative to the morphological directions, e.g. of crystal surfaces, crystal needles or fibers, provide an important signature of the material. This method is also used in the diagnosis of bio-crystals (e.g. gout and pseudo-gout).

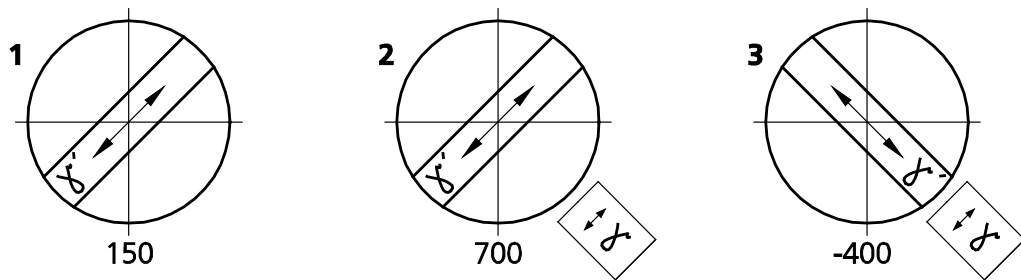

Fig. 4-8 Determining the polarization direction n_{γ} using a synthetic fiber as an example

(2) Instrumentation

- Eyepiece with crossline reticle
- Strain-free objectives
- Pol rotary stage (Fig. 4-7/1)
- Polarizer D (rotatable or fixed)
- Screw-in fixed analyzer slider D or lambda compensator or lambda/4 compensator combined with analyzer (in Axiolab 5 tubes)
- Pol adjustment tool sample for polarization microscope (453679-0000-000)

(3) Configuring the microscope

- Adjust the microscope as described in section 4.2.1 (3) for transmitted light brightfield microscopy. Make sure the inter-pupillary distance is adjusted correctly on the binocular tube (see section 4.1.1).
- Center the Pol rotary stage (Fig. 4-7/1) and objectives (see sections 3.1.7.5 and 3.1.7.6).
- Swivel the polarizer (Fig. 4-7/3) into the beam path and, if it is rotatable, position it at 0° .
- Insert the analyzer slider (Fig. 4-7/2) into the slot for compensators or in the intermediate plate (if tube does not already have an analyzer). The field of view will appear dark due to the crossed polarizers. If not, align the analyzer in the tube or the intermediate plate.
- Place the Pol adjustment tool sample on the microscope stage and rotate it until the sample appears dark.

- Remove the analyzer from the beam path and align the reticle along the split cracks of the sample.
- Subsequently reinsert the analyzer and remove the Pol adjustment tool sample. The pass directions of the polarizer and analyzer will now be parallel to the reticle (Polarizer EW, Analyzer NS).

**NOTE**

It is not necessary to adjust the reticle when working with the intermediate plate and the binocular photo tube Pol (425520-9100-000).

- Rotate the Pol rotary stage with the sample, e.g. a synthetic fiber, until the sample appears as dark as possible. In this position, the fiber extends parallel to one of the two directions of the crossline reticle.

**NOTE**

Do not change the inter-pupillary distance on the binocular tube, as the angle of the crossline reticle to the fiber will be changed.

- Now rotate the stage by 45° so that the longitudinal axis of the fiber is oriented NE-SW (Fig. 4-9). The sample will display the greatest brightness here (diagonal position). In this position the sample may have any color.
- Insert the lambda compensator (possible only if used with screw-in analyzer in tube or intermediate plate).

Like the sample, the lambda compensator is a birefringent object, albeit with a defined path difference of 550 nm and the principal polarization direction n_γ definitely oriented in a NE-SW direction.

When the lambda compensator is moved into the beam path, the sample changes its color. The type of color change depends on the orientation of the sample (NE-SW or NW-SE).

The changes in color are attributable to optical interference. The interference colors (path differences) in both diagonal positions (NE-SW and NW-SE) of the sample must be compared in this connection.

The path difference results from the superposition (interference) of the polarization direction of the sample over the polarization direction of the lambda compensator.

The largest path difference occurs when the polarization direction of the sample with the absolutely or relatively highest refractive index (n_γ or $n_{\gamma'}$) is parallel to the principal polarization direction of the lambda compensator. The sample will then appear greenish-blue, for example (Fig. 4-8/2).

The smallest path difference occurs when the polarization direction of the sample with the absolutely or relatively lowest refractive index (n_α or $n_{\alpha'}$) is perpendicular to the polarization direction of the lambda compensator. The sample will then appear yellow, for example (Fig. 4-8/3).

(4) Conclusions

The gray-white color appearing first in the bright position in the above example (Fig. 4-8/1) corresponds to a path difference of 150 nm according to the Michel-Lévy color chart (Fig. 4-9).

When the lambda compensator is brought into the beam path, the non-birefringent "surroundings" of the synthetic fiber appear dark red, which corresponds to the path difference of the compensator of 550 nm (1st order interference color for the path difference of 550 nm corresponds to 1λ).

If the polarization direction (n_{γ} or $n_{\gamma'}$) of the birefringent sample to be examined is parallel to the principal polarization direction (n_{γ}) of the lambda compensator, i.e. in the NE-SW direction, the path difference of the sample (e.g. gray-white: 150 nm) and the path difference of the lambda compensator (red: 550 nm) add up. This results in a color change of the sample from grayish white to greenish-blue (resulting path difference = 700 nm).

If the polarization direction of the birefringent sample to be examined is perpendicular to the principal polarization direction of the lambda compensator, i.e. in the NW-SE direction, the path difference of the sample (e.g. gray-white: 150 nm) is subtracted from the path difference of the compensator (red: 550 nm). In this case, the interference color of the sample visibly changes from gray-white to orange (resulting path difference = 400 nm).

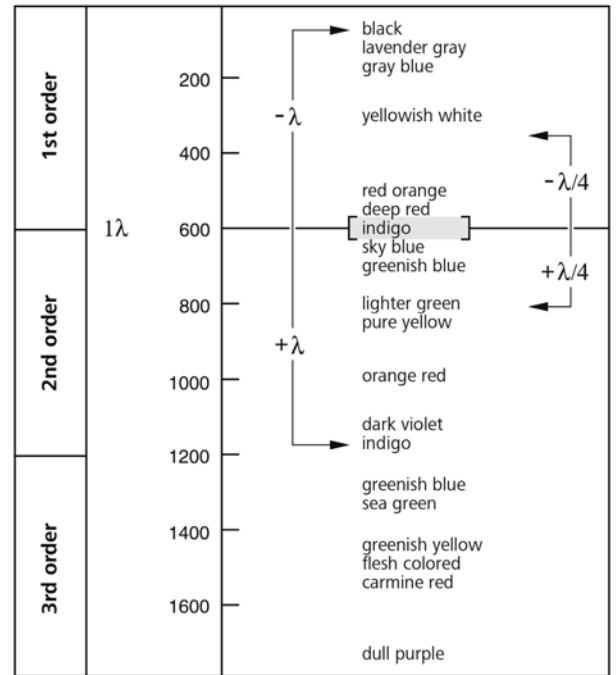



Fig. 4-9 Schematic diagram of the color charts developed by Michel-Lévy

	NOTE
The Michel-Lévy color tables are available in the literature catalog no. 42-312.	

4.2.4.3 Measuring path differences

The measurement compensators are required for the exact measurement of path differences. These return, i.e. compensate, the path difference created by the specimen to zero (black of the first order).

Whereas in the above-described methods the addition or subtraction position was of interest, **only** the subtraction position is of interest in the measurement.

Path differences in the specimen can assume very small values ($1/50 \lambda$ or 10 nm) and very large values (greater than 10λ or approx. 5500 nm and higher) and thus determine the compensator appropriate for the measurement.

The suitable compensator is determined as follows:

- Configure the microscope as for transmitted light brightfield microscopy (see section 4.2.1), taking care to ensure the correct inter-pupillary distance in the binocular tube (see section 4.1.1).
- Accurately position the specimen to be examined on the center of the reticle.
- Limit the aperture to a value of about 0.2.
- Turn the Pol rotary stage until the specimen is almost extinguished, i.e. **completely dark**, and set the 45° locking position.
- Rotate the stage **once** (by 45°) so that the specimen is in a diagonal position (sample becomes bright).

The interference intensity or color leads to the following conclusion:

- If more or less strong interference colors appear on the specimen, the path difference ranges approximately between $1/2 \lambda$ and 5λ .

The suitable compensator is:

B 0-5 λ tilting compensator

- If the specimen-side color changes from light gray/white to a strong interference color, when a lambda compensator (473704-0000-000) is inserted in the compensator slot, the path difference is $(1/4 - 1/2) \lambda$.



NOTE

A prerequisite for the occurrence of the color change effect may be the evaluation in two specimen positions rotated at an angle of 90° from one another, plus a centered stage.

The suitable compensator is:

B 0-5 λ tilting compensator or the DE SENARMONT compensation method up to 1λ using the **546/4 nm Senarmont compensator**.



NOTE

The DE SENARMONT compensation method requires the use of the rotatable analyzer.

- After insertion of the lambda compensator and rotation of the specimen by 90°, the interference color remains white; in this case, however, it is a "higher-order white" and thus the path difference is $> 5 \lambda$.

-
- The suitable compensator is:
K 0-30 λ tilting compensator (Accessory 000000-1115-698)
 - A dark gray appearing as the interference color indicates a very small path difference ($\lambda/10$ or 54.6 nm).
 - Insert the compensator into the slot as far as it will go.

The accompanying instructions must be observed for the measurement preparation and procedure.

4.2.4.4 Circular polarization contrast

(1) Application

Unlike standard polarization contrast, circular polarization contrast does not show any dark (extinction) positions that depend on the angle of rotation (azimuth) of the specimen relative to the polarizer or analyzer. This means that when the stage is rotated the same image impression remains, as the light/dark positions are omitted. With optical anisotropy, all transparent specimens display the characteristic interference colors.

(2) Instrumentation

- Strain-free objectives
- Pol rotary stage
- Circular polarizer D (no polarizers may be adapted on the condenser) including corresponding $\lambda/4$ plate.
- Stationary analyzer slider D or screw-in analyzer (in Axiolab 5 tubes).

(3) Configuring the microscope

- Set the microscope as for transmitted light brightfield microscopy using the KÖHLER method (see section 4.2.1).
- Center the Pol rotary stage or objective (if this has not already been done – see sections 3.1.7.5 and 3.1.7.6).
- Initially do **not** use a specimen for the further settings.
- Place the analyzer in position.
- Swivel the lower part of the circular polarizer D (Fig. 4-10/2) into the beam path until it engages and evaluate the extinction (darkening) of the field of view without the specimen at full light intensity. If this is not optimal, align the analyzer in the tube or intermediate plate as necessary.
- Insert the respective slider 6x20mm with the $\lambda/4$ plate (Fig. 4-10/1) as far as it will go into the slot for compensators above the nosepiece.

- Then swivel the upper part of the circular polarizer D (Fig. 4-10/4) into the beam path.
- Rotate the lever of the lambda/4 plate of the circular polarizer D (Fig. 4-10/3) until maximum extinction is achieved (dark-gray field of view) (lever points 45° to the right).

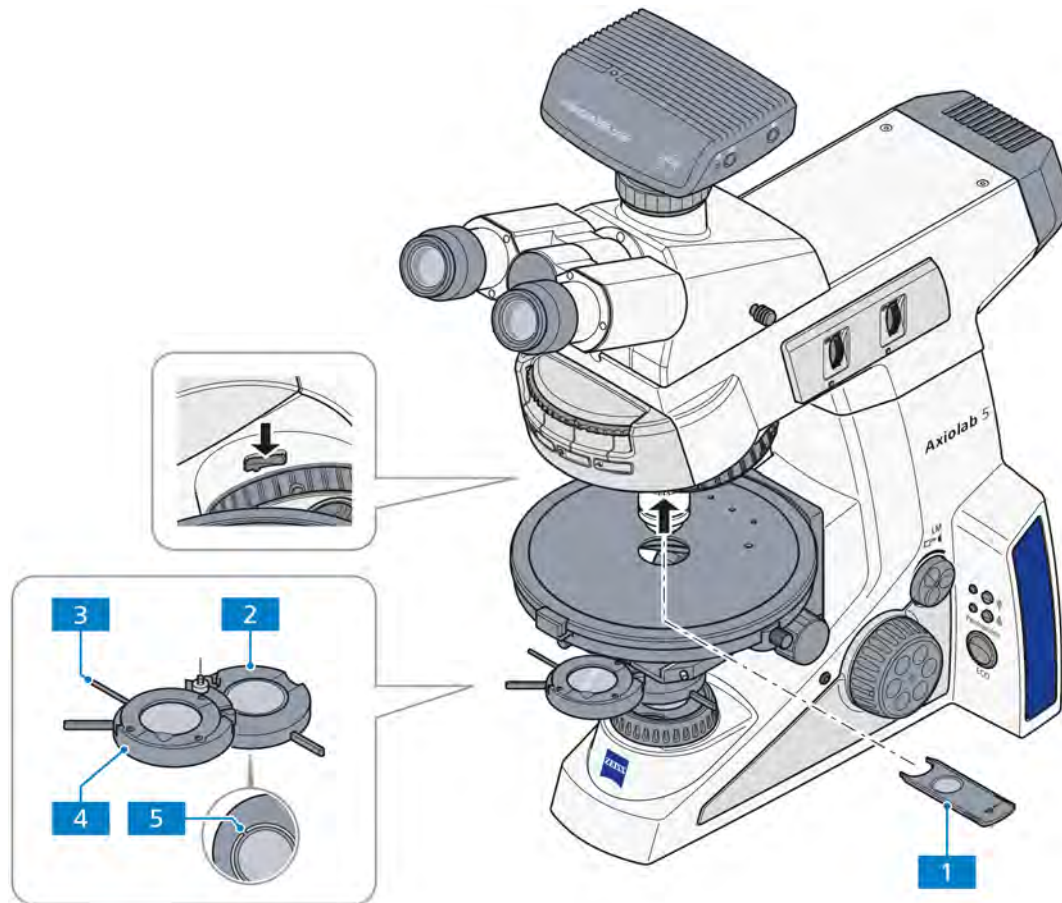

- 1 Slider 6x20mm with lambda/4 plate
- 2 Lower section of circular polarizer
- 3 Lever for rotating the lambda/4 plate
- 4 Lambda/4 plate in the upper part of the circular polarizer
- 5 Adjustment slits

Fig. 4-10 Components for circular polarization contrast

- An (anisotropic) specimen should not be examined until after the above adjustment.
- Reinsert the specimen to be examined.

The interference colors – which depend on the material, specimen thickness and orientation – of the specimens appear constant and independent of stage rotation.

**NOTE**

For a high-contrast image with higher-magnification objectives (from approx. 20x) the illumination aperture must be reduced to a value between 0.15 and 0.20, i.e. the aperture diaphragm must be closed accordingly.

The effect of the lambda/4 plate (Fig. 4-10/4) can be undone by either swiveling it out of the beam path or turning it with the lever (Fig. 4-10/3) into one of its two click-stop positions.

(4) Sample differentiation between gout and pseudo-gout

- Move two polarizers to the dark position (the analyzer is oriented NORTH-SOUTH, while the polarizer is oriented EAST-WEST).
- Swivel in the lambda plate and, if a **rotary** lambda plate is available (e.g. 445226-0000-000), set the oscillation direction to 45° (γ , stop position).
- Select crystal needles that are oriented in the gamma direction (see marking on the lambda plate).

(5) Analysis

- If the crystal needles oriented parallel to the gamma direction of the lambda plate are yellow, and the crystal needles lying at a right angle to the gamma direction are blue, the crystals are monosodium urate crystals (gout).
- If the crystal needles oriented parallel to the gamma direction of the lambda plate are blue, and the crystal needles lying at a right angle to the gamma direction are yellow, the crystals are calcium pyrophosphate crystals (pseudo-gout).

This analysis is also possible using a polarizer with a fixed lambda plate which can be placed on the luminous-field diaphragm. In that case, the lambda plate does not have to be rotated.

4.2.5 Configuring transmitted light polarization with the conoscopy stand

4.2.5.1 Determining the optical character of crystals

For the classification (and thus identification) of crystalline material – instead of the observation of the specimen itself – the analysis of an interference image in the objective pupil provides the more valuable information. This image is visible in the eyepiece when an additional lens (so-called Bertrand lens) is switched on. Alternatively, the auxiliary microscope or a diopter may be used to view the interference image.

In contrast to orthoscopy, this is referred to as conoscopy, because the illumination is ideally provided by a wide open cone. In practice this means that the aperture diaphragm is fully open and the objective should likewise have a high aperture.

(1) Application

Crystal analysis is used to determine the optical character of transparent and weakly absorbent crystals. This method is also referred to as conoscopy.

Its main application is classic mineral microscopy. However, synthetic crystals, industrial minerals and plastics (e.g. films) can also be identified and characterized.

(2) Instrumentation

Conoscopic viewing is preferably carried out on the Axiolab 5 microscope for transmitted light conoscopy.

- Strain-free objectives; recommended:
N-Achroplan 50x/0.8 Pol objective or
EC Plan-Neofluar 40x/0.9 Pol objective
- Pol rotary stage
- Polarizer D (rotatable or fixed)
- 0.9 Pol condenser

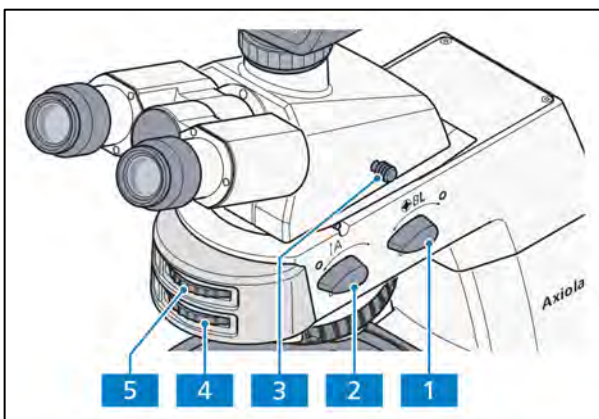



Fig. 4-11 Axiolab 5 for transmitted light conoscopy

(3) Configuring the microscope for conoscopy

In the case of uniaxial crystals, the most favorable orientation for conoscopic viewing is obtained with those specimen features (e.g. of a thin section) that in orthoscopic viewing change the brightness as little as possible. In this case, the direction of viewing and the optical axis are parallel. The same applies to biaxial crystals if viewed in or approximately in the direction of one of the two optical axes.

- Configure the microscope as for transmitted light brightfield microscopy using the KÖHLER method (see section 4.2.1).
- Place the specimen on the stage and focus on it.
- Swivel the analyzer into the beam path (**on** position) with rotary knob **A** (Fig. 4-11/2).

- The polarization direction can be changed using the setting wheel (Fig. 4-11/4) of the analyzer.

	ATTENTION
<p>The movements of rotary knobs A and BL and the respective setting wheels are coupled with each other. Only one control element should therefore be operated at a time and the movement of the other should not be inhibited or blocked. Otherwise, mechanical damage may occur.</p>	

	NOTE
<p>If the rotary knob BL is set to the On position, rotary knob A is automatically moved into the On position if it is not there already. If, on the other hand, rotary knob A is set to the Off position, rotary knob BL is automatically moved into the Off position if it is not there already.</p>	

- Place a selected crystal in the center of the crossline reticle.
- Swivel in the N-Achroplan 50x/0.8 Pol objective or EC Plan-Neofluar 40x/0.9 Pol objective and focus using the focusing drive.
- If necessary, close the luminous-field aperture to avoid superimposition of axial figures of neighboring crystals on the axial figure to be examined. The smallest crystal value that can be faded out is 170 µm.
- Switch on Bertrand lens **BL** (Fig. 4-11/1) (**On** position). The axial figure will appear in the field of view.
- Bring the axial figure into focus using the setting wheel (Fig. 4-11/5).

(4) Evaluation

Crystalline anisotropic specimens can be separated into optical uni- and biaxial specimens, in each case with an "optically positive" or "negative" character.

Uniaxial crystals display a **black cross** when the optical axis is parallel to the direction of view. **Depending on the level of birefringence and specimen thickness**, concentrically arranged colored **interference rings** (so-called isochromes) may appear (see also Fig. 4-12, second row).

The lines of this black cross remain closed when the stage is rotated. Depending on the section it may lie within or outside the displayed objective pupil.

With **optically biaxial** crystals, the cross resolves into two **dark hyperbola branches** (the so-called isogyres) **depending on stage rotation**, which are surrounded by colored interference patterns depending on the amount of birefringence and specimen thickness (suggestive of the figure "8").

Inserting a lambda compensator (473704-0000-000) or lambda/4 (473714-0000-000) or a 0-4 lambda wedge compensator (000000-1140-663) in the compensator slot with the initial state of the axial figure being as illustrated in Fig. 4-12 results in the following changes in color (shown schematically as blue and yellow areas) to the axial figure, thus allowing differentiation in "optically positive" and "optically negative".

	Optically uniaxial		Optically biaxial		
	Positive	Negative	Positive	Negative	
Lambda plate (white → blue → yellow)					+ = Blue - = Yellow
Quartz wedge (Direction of motion at insertion)					↗ Direction of movement ↘
Lambda/4 plate (position of black spots)					

Fig. 4-12 Determining optical character

In the case of less favourable sections in which the cross-hair center is optically uniaxial or the isogyres are optically biaxial specimens outside the objective pupil, an assessment is possible as follows:

- If the black isogyres are **straight** and they run parallel to the pupil (in relation to the cross-hairs), the specimen is **optically uniaxial**.
- If the black isogyres are **curved lines** which wander on a circular path through the pupil, the specimen is **optically biaxial**.

	<p>NOTE</p> <p>Axial figures can often be better displayed with circular polarization. In particular, the axis angle of optically biaxial specimens (quasi the distance between the isogyres) can be determined more clearly. The optical character can also be determined. The lambda compensator (6x20mm), arranged in the compensator slot, is used for this purpose.</p>
--	---

	<p>NOTE</p> <p>Two storage compartments for 6x20mm slides are located on the back side of the conoscopy stand.</p>
--	---

4.2.5.2 Detecting birefringence with the Axiolab for conoscopy

(1) Application

The transmitted light polarization method is used for samples which change the polarization of the light. Such samples are called birefringent. Examples include crystals, minerals or polymers. If such birefringent substances are observed between crossed polarizers, the birefringent portion of the sample appears bright while it's surrounding remains dark.

A birefringent substance can be recognized by rotating the sample by 360° between crossed polarizers. The sample should show four bright and four dark appearances during the rotation. During the rotation procedure, interference colors appear that range from gray (mostly for biological samples) through white, yellow and red to blue, depending on the birefringence, thickness and orientation of the sample. The interference colors may be of the first or a higher order.

(2) Instrumentation

On the Axiolab 5 microscope for transmitted light conoscopy:

- Strain-free objectives
- Pol rotary stage
- Polarizer D (rotatable or fixed)
- Analyzer slider D
- Lambda compensator or lambda/4 compensator



NOTE

The depolarizer is already incorporated in the Axiolab 5 stand for conoscopy.

A depolarizer (quartz depolarizer) should be installed in all microscopes used for examining mineral/geological specimens.

A depolarizer extinguishes undesirable polarization effects (e.g. false or pseudo-pleochroism) that may occur behind the analyzer (e.g. on prism surfaces in the tube), or shifts them to higher orders.

(3) Configuring the microscope

- Configure the microscope as for transmitted light brightfield microscopy using the KÖHLER method (see section 4.2.1 (3)).
- Center the Pol rotary stage (Fig. 4-13/1) (see section 3.1.7.5) and objectives (see section 3.1.7.6).
- Swing the polarizer (Fig. 4-13/3) into the beam path and, if it is rotatable, position it at 0° .
- Put the analyzer slider (Fig. 4-13/2) into the beam path and adjust it using the setting wheel until the field of view is dark.
- Bring the specimen to be examined into the field of view and rotate it with the rotary stage. Normally, birefringent (anisotropic) objects will now show the same color and intensity variations as described above during rotation between crossed polarizers. Optically anisotropic substances may remain dark when an isotropic direction, e.g. from optically single-axis or double-axis crystals, is put parallel to the observation direction.

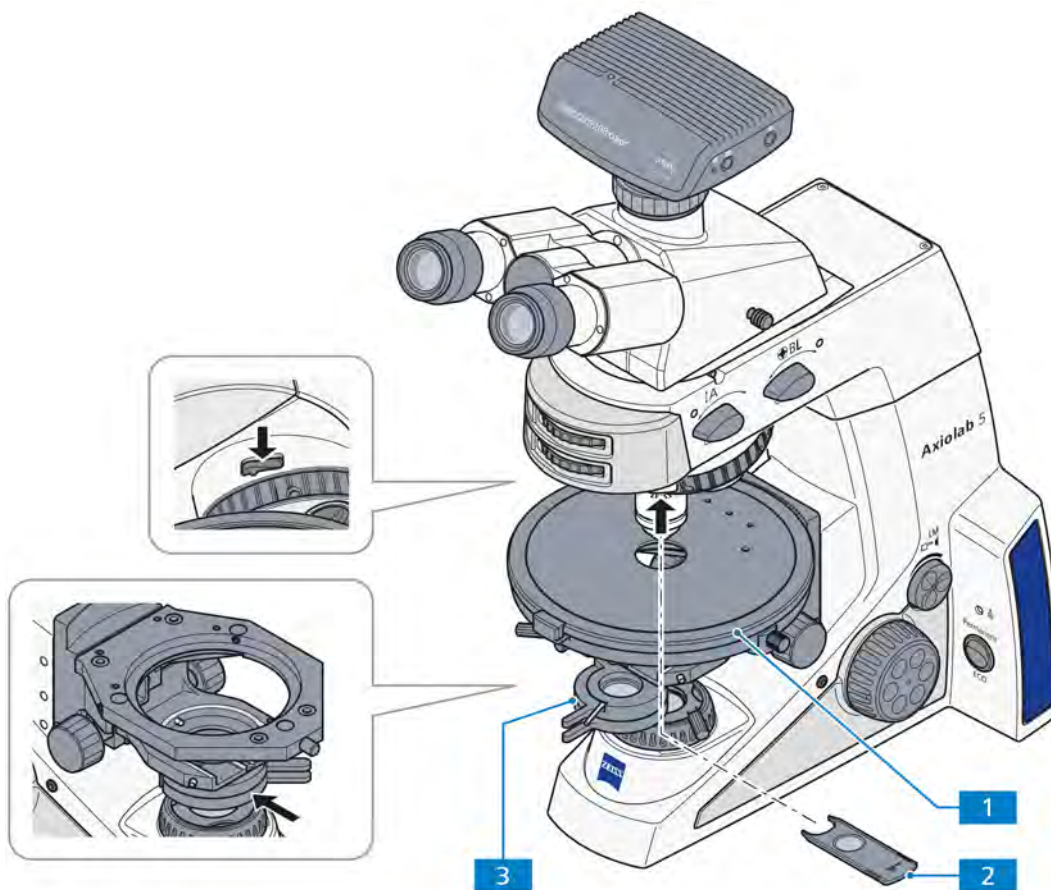

Fig. 4-13 Components for transmitted light polarization on the conoscopy stand

4.2.5.3 Determining the polarization direction $n_{\gamma'}$

(1) Application

The determination of the polarization direction of n_{γ} or $n_{\gamma'}$ respectively (polarization direction with the absolute or relative largest index of refraction) and n_{α} or $n_{\alpha'}$ respectively (polarization direction with the absolute or relative smallest index of refraction) relative to the morphological directions, e.g. of crystal surfaces, crystal needles or fibers, provide an important signature of the material. This method is also used in the diagnosis of bio-crystals (e.g. gout and pseudo-gout).

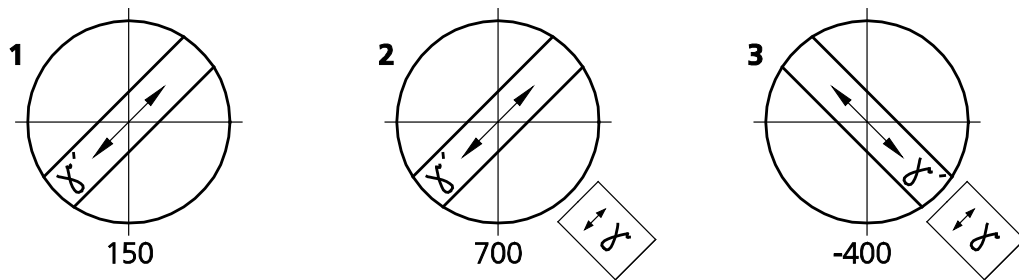

Fig. 4-14 Determining the polarization direction $n_{\gamma'}$ using a synthetic fiber as an example

(2) Equipment configuration for Axiolab for conoscopy

- Eyepiece with crossline reticle
- Strain-free objectives
- Pol rotary stage (Fig. 4-13/1)
- Polarizer D (rotatable or fixed)
- Lambda or lambda/4 compensator as required
- Pol adjustment tool sample for polarization microscope (453679-0000-000)

(3) Configure the microscope

- Configure the microscope as for transmitted light brightfield microscopy (see section 4.2.1 (3)), taking care to ensure the correct inter-pupillary distance in the binocular tube (see section 4.1.1).
- Center the Pol rotary stage (Fig. 4-7/1) and objectives (see sections 3.1.7.5 and 3.1.7.6).
- Swivel the polarizer (Fig. 4-7/3) into the beam path and, if it is rotatable, position it at 0° .
- Insert the analyzer slider into the beam path and bring it into a crossed position using the setting wheel. The field of view will appear dark due to the crossed polarizers.
- Place the Pol adjustment tool sample on the microscope stage and rotate it until the sample appears dark.
- Remove the analyzer slider from the beam path and align the reticle along the split cracks of the sample.

- Subsequently reinsert the analyzer slider and remove the Pol adjustment tool sample. The pass directions of the polarizer and analyzer will now be parallel to the crossline reticle (polarizer EW, analyzer NS).

**NOTE**

An adjustment of the crossline reticle is not necessary when working with the intermediate plate and the binocular photo tube Pol (425520-9100-000).

- Rotate the rotary stage Pol with the sample, e.g. a synthetic fiber, until the sample appears as dark as possible. In this position, the fiber extends parallel to one of the two directions of the crossline reticle.

**NOTE**

Do not change the inter-pupillary distance on the binocular tube, as the angle of the crossline reticle to the fiber will be changed.

- Now turn the stage on by 45° so that the longitudinal axis of the fiber is oriented NE-SW (Fig. 4-15). The sample will display the greatest brightness here (diagonal position). In this position the sample may have any color.
- Insert the lambda compensator (473704-0000-000).

Like the sample, the lambda compensator is a birefringent object, albeit with a defined path difference of 550 nm and the principal polarization direction n_γ definitely oriented in a NE-SW direction.

When the lambda compensator is moved into the beam path, the sample changes its color. The type of color change depends on the orientation of the sample (NE-SW or NW-SE).

The changes in color are attributable to optical interference. The interference colors (path differences) in both diagonal positions (NE-SW and NW-SE) of the sample must be compared in this connection.

The path difference results from the superimposition (interference) of the polarization direction of the sample over the polarization direction of the lambda compensator.

The largest path difference occurs when the polarization direction of the sample with the absolute or relative highest refractive index (n_γ or $n_{\gamma'}$) is parallel to the principal polarization direction of the lambda compensator. The sample will then appear greenish-blue, for example (Fig. 4-14/2).

The smallest path difference occurs when the polarization direction of the sample with the absolute or relative lowest refractive index (n_α or $n_{\alpha'}$) is perpendicular to the polarization direction of the lambda compensator. The sample will then appear yellow, for example (Fig. 4-14/3).

(4) Conclusions

The gray-white color appearing first in the bright position in the above example (Fig. 4-14/1) corresponds to a path difference of 150 nm according to the Michel-Lévy color chart (Fig. 4-15).

When the lambda compensator is brought into the beam path, the non-birefringent "surroundings" of the synthetic fiber appear dark red, which corresponds to the path difference of the compensator of 550 nm (1st order interference color for the path difference of 550 nm corresponds to 1λ).

If the polarization direction (n_{γ} or $n_{\gamma'}$) of the birefringent sample to be examined is parallel to the principal polarization direction (n_{γ}) of the lambda compensator, i.e. in the NE-SW direction, the path difference of the sample (e.g. gray-white: 150 nm) and the path difference of the lambda compensator (red: 550 nm) add up. This results in a color change of the sample from grayish white to greenish-blue (resulting path difference = 700 nm).

If the polarization direction of the birefringence sample to be examined is perpendicular to the principal polarization direction of the lambda compensator, i.e. in the NW-SE direction, the path difference of the sample (e.g. gray-white: 150 nm) is subtracted from the path difference of the compensator (red: 550 nm). In this case, the interference color of the sample visibly changes from gray-white to orange (resulting path difference = 400 nm).

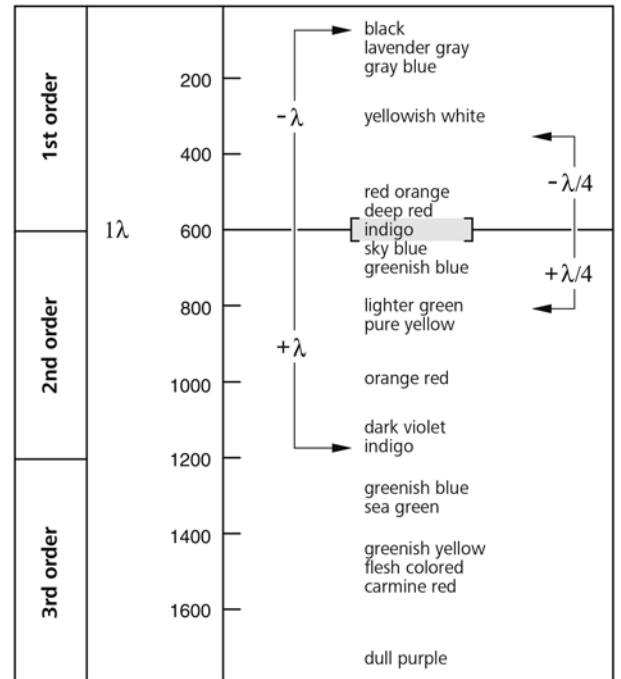



Fig. 4-15 Schematic diagram of the color charts according to Michel-Lévy

	NOTE
The Michel-Lévy color charts are available in the literature catalog no. 42-312.	

4.2.5.4 Measuring path differences with the Axiolab for conoscopy

The measurement compensators are required for exact measurement. These return, i.e. compensate, the path difference created by the specimen to zero (black of the first order).

Whereas in the above-described methods the addition or subtraction position was of interest, **only** the subtraction position is of interest in the measurement.

Path differences in the specimen can assume very small values ($1/50 \lambda$ or 10 nm) and very large values (more than 10λ or approx. 5500 nm and more) and thus determine the compensator appropriate for the measurement.

The suitable compensator is determined as follows:

- Configure the microscope as for transmitted light brightfield microscopy (see section 4.2.1), taking care to ensure the correct inter-pupillary distance in the binocular tube (see section 4.1.1).
- Accurately position the specimen to be examined on the center of the crossline reticle.
- Limit the aperture to a value of about 0.2.
- Rotate the Pol rotary stage until the specimen is almost invisible, i.e. **completely dark**.
- Rotate the stage **once** (by 45°) so that the specimen is in a diagonal position (bright).

The interference intensity or color leads to the following conclusions:

- If more or less strong interference colors appear on the specimen, the path difference ranges from approximately $1/2 \lambda$ to 5λ .
The suitable compensator is:
the **B 0-5 λ tilting compensator**.
- If the specimen-side color changes from light gray/white to a strong interference color when a lambda compensator (473704-0000-000) is inserted in the compensator slot, the path difference is $(1/4 - 1/2) \lambda$.

**NOTE**

A prerequisite for the occurrence of the color change effect may be the evaluation in two specimen positions rotated at an angle of 90° from each other, plus a centered stage.

The suitable compensator is:

the **B 0-5 λ tilting compensator** or the DE SENARMONT compensation method up to 1λ using the **546/4 nm Senarmont compensator**.

**NOTE**

The DE SENARMONT compensation method requires the use of the rotatable analyzer.

- After insertion of the lambda compensator and rotation of the specimen by 90°, the interference color remains white; in this case, however, it is a "higher-order white" and thus the path difference is $> 5 \lambda$.
The suitable compensator is:
the **K 0-30 λ tilting compensator** (Accessory 000000-1115-698)
- A dark gray as the interference color indicates very small path differences ($\lambda/10$ or 54.6 nm).
- Insert the compensator into the slot as far as it will go.

The accompanying instructions must be followed for the measurement preparation and procedure.

4.2.5.5 Circular polarization contrast with Axiolab for conoscopy

(1) Application

Unlike standard polarization contrast, circular polarization contrast does not show any dark (extinction) positions that depend on the angle of rotation (azimuth) of the specimen relative to the polarizer or analyzer. This means that when the stage is rotated, the image impression remains the same, as the light/dark positions are omitted. With optical anisotropy, all transparent specimens display the characteristic interference colors.

(2) Instrumentation

- Strain-free objectives
- Pol rotary stage
- Circular polarizer D (no polarizers may be adapted on the condenser) including corresponding the lambda/4 plate.

(3) Configuring the microscope

- Configure the microscope as for transmitted light brightfield microscopy using the KÖHLER method (see section 4.2.1).
- Center the Pol rotary stage or objective (if this has not already been done – see section 3.1.7.5 or 3.1.7.6).
- Initially, do **not** use a specimen for the further settings.
- Swivel the analyzer into the beam path.
- Swivel the lower part of the circular polarizer D (Fig. 4-16/2) into the beam path until it engages and evaluate the extinction (darkening) of the field of view without the specimen at full light intensity. If this is not optimal, align the analyzer as necessary.
- Insert the respective 6x20mm slider with the lambda/4 plate (Fig. 4-16/1) as far as it will go into the slot for compensators above the nosepiece.
- Then swivel the upper part of the circular polarizer D (Fig. 4-16/4) into the beam path.
- Rotate the lever of the lambda/4 plate of the circular polarizer D (Fig. 4-16/3) until extinction is maximized (dark-gray field of view) (lever points 45° to the right).

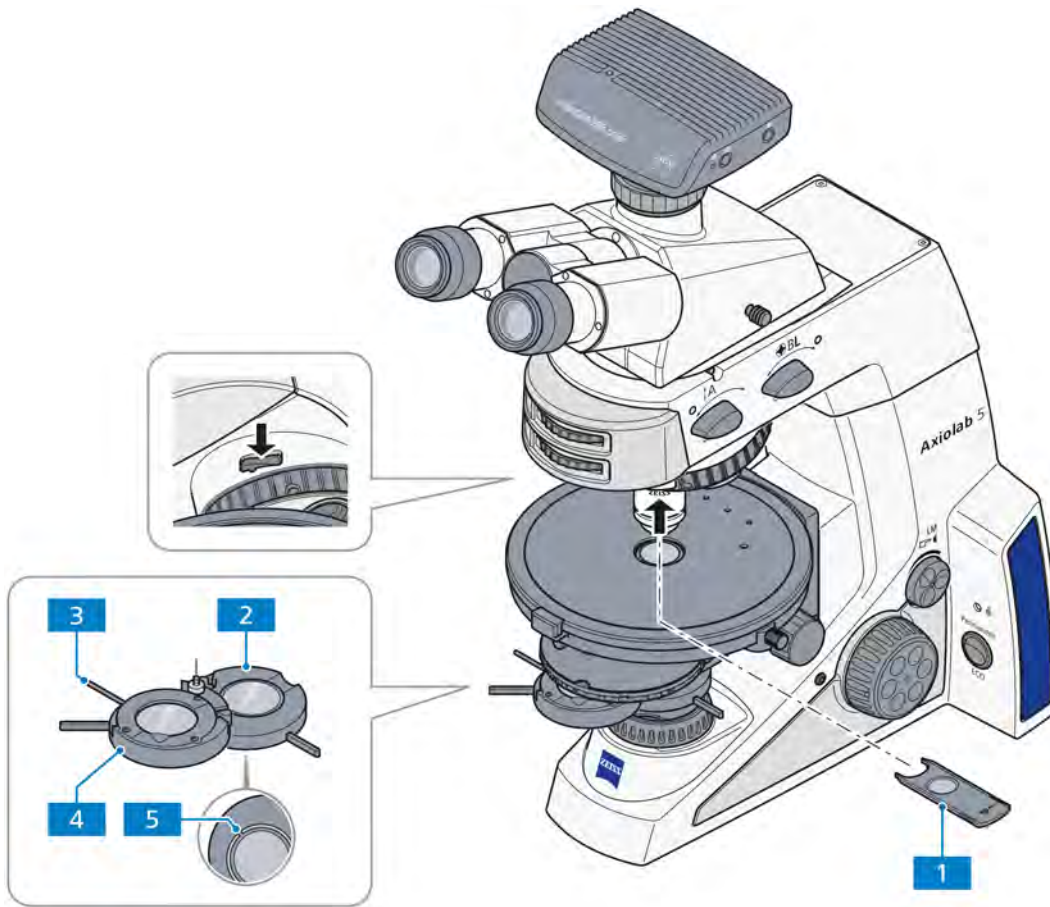

- 1 6x20mm slider with lambda/4 plate
- 2 Lower section of circular polarizer
- 3 Lever for rotating the lambda/4 plate
- 4 Lambda/4 plate in the upper part of the circular polarizer
- 5 Adjustment slits

Fig. 4-16 Components for circular polarization contrast on conoscopy stand

- An (anisotropic) specimen should not be examined until after the above adjustment has been completed.
- Reinsert the specimen to be examined.

The interference colors – which depend on the material, specimen thickness and orientation – of the specimens appear constant and independent of stage rotation.



NOTE

For a high-contrast image with higher-magnification objectives (from approx. 20x) the illumination aperture must be reduced to a value between 0.15 and 0.20, i.e. the aperture diaphragm must be closed accordingly.

The effect of the lambda/4 plate (Fig. 4-16/4) can be undone by either swiveling it out of the beam path or turning it with the lever (Fig. 4-16/3) to one of its two click-stop positions.

4.2.6 Configuring transmitted light polarization for conoscopic observation – determining the optical character of crystals

For the classification (and thus identification) of crystalline material, the analysis of an interference image in the objective pupil provides more valuable information than the examination of the specimen itself. This image is visible in the eyepiece when an additional lens (known as a Bertrand lens) is switched on. Alternatively, the auxiliary microscope or a diopter may be used to view the interference image.

In contrast to orthoscopy, this is referred to as conoscopy, because the illumination is ideally provided by a wide open cone. In practice this means that the aperture diaphragm is fully open and the objective should likewise have a large aperture.

4.2.6.1 Application

Crystal analysis is used to determine the optical character of transparent and weakly absorbent crystals. This method is also referred to as conoscopy.

Its main application is classic mineral microscopy. However, synthetic crystals, industrial minerals and plastics (e.g. films) can also be identified and characterized.

(1) Instrumentation

Conoscopic viewing is preferably carried out on the Axiolab 5 microscope for transmitted light conoscopy.

- Strain-free objectives; recommended:
N-Achroplan 50x/0.8 Pol objective or
EC Plan-Neofluar 40x/0.9 Pol objective
- Pol rotary stage
- Polarizer D (rotatable or fixed)
- 0.9 Pol condenser

(2) Configuring the microscope for conoscopy

In the case of uniaxial crystals, the most favorable orientation for conoscopic viewing is obtained with those specimen features (e.g. of a thin section) that in orthoscopic viewing change the brightness as little as possible. In this case, the direction of viewing and the optical axis are parallel. The same applies to biaxial crystals if viewed in or approximately in the direction of one of the two optical axes.

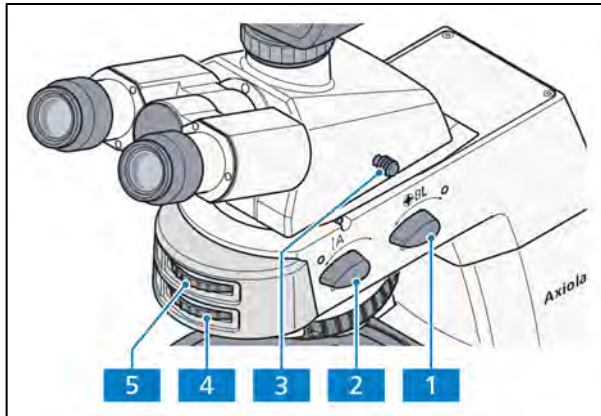

Fig. 4-17 Axiolab 5 for transmitted light conoscopy

- Configure the microscope as for transmitted light brightfield microscopy using the KÖHLER method (see section 4.2.1).
- Swivel the polarizer (Fig. 4-13/3) into the beam path and, if it is rotatable, position it at 0°.
- Swivel the analyzer into the beam path and bring into a crossed position with the setting wheel. (The field of view will now appear dark)
- Place the specimen on the stage and focus on it.
- Swivel the analyzer into the beam path (**On** position) with rotary knob **A** (Fig. 4-17/2). The polarization direction can be changed using the setting wheel (Fig. 4-17/4) of the analyzer.



ATTENTION

The movements of rotary knobs **A** and **BL** and the respective setting wheels are coupled to each other. Only **one** control element should therefore be operated at a time and the movement of the other should not be inhibited or blocked. Otherwise, mechanical damage may occur.



NOTE

If rotary knob **BL** is set to the **On** position, rotary knob **A** will be automatically set to the **On** if it is not already there.
If, on the other hand, rotary knob **A** is set to the **Off** position, rotary knob **BL** will be automatically set to the **Off** position if it is not already there.

- Place a selected crystal in the center of the crossline reticle.
- Swivel in the objective N-Achroplan 50x/0.8 Pol or EC Plan-Neofluar 40x/0.9 Pol and focus with the focusing drive.
- If necessary, close the luminous-field aperture to avoid superimposition of axial figures of neighboring crystals on the axial figure. The smallest crystal range that can be faded out is approx. 170 µm.
- Switch on the Bertrand lens **BL** (Fig. 4-17/1) (Position **On**). The axial figure will appear in the field of view.
- Bring the axial figure into focus with the setting wheel (Fig. 4-17/5).

(3) Evaluation

Crystalline anisotropic specimens can be separated into optical uni- and biaxial, in each case with an "optically positive" or "negative" character.

Uniaxial crystals display a **black cross** when the optical axis is parallel to the direction of view. **Depending on the level of birefringence and the specimen thickness**, concentrically arranged colored **interference rings** (so-called isochromes) may appear (see also Fig. 4-12, second row).

The lines of this black cross remain closed when the stage is rotated. Depending on the section it may lie within or outside the displayed objective pupil.

With **optically biaxial** crystals, the cross resolves into two **dark hyperbola branches** (the so-called isogyres) **depending on stage rotation**, which are surrounded by colored interference patterns depending on the amount of birefringence and specimen thickness (suggestive of the figure "8").

Inserting a lambda compensator (473704-0000-000) or a lambda/4 (473714-0000-000) or a 0-4 lambda wedge compensator (000000-1140-663) in the compensator slot with the initial state of the axial figure being as illustrated in Fig. 4-18 results in the following changes in color (shown schematically in the blue and yellow areas) of the axial figure, thus allowing differentiation in "optically positive" and "optically negative".

	Optically uniaxial		Optically biaxial		
	Positive	Negative	Positive	Negative	
Lambda plate (white → blue → yellow)					+ = Blue - = Yellow
Quartz wedge (Direction of motion at insertion)					↗ Direction of ↖ movement
Lambda/4 plate (position of black spots)					

Fig. 4-18 Determining the optical character

In the case of less favorable sections in which the cross-hair center is optically uniaxial or the isogyres are optically biaxial specimens outside the objective pupil, an assessment can be done as follows:

- If the black isogyres are **straight** and they run parallel to the pupil (in relation to the cross-hairs), the specimen is **optically uniaxial**.
- If the black isogyres are **curved lines** which wander on a circular path through the pupil, the specimen is **optically biaxial**.

NOTE
Axial figures can often be better displayed with circular polarization. In particular, the axis angle of optically biaxial specimens (quasi the distance between the isogyres) can be better determined. The optical character can also be determined. The lambda compensator (6x20mm), arranged in the compensator slot, is used for this purpose.

NOTE
Two storage compartments for 6x20mm slides are located at the back of the conoscopy stand.

4.3 Illumination and contrast methods in reflected light

4.3.1 Configuring reflected light brightfield microscopy using the KÖHLER method

(1) Application

Reflected light brightfield microscopy is the simplest and most common optical microscopy method for examining opaque samples or specimens, e.g. material sections or wafers.

For a true-to-object imaging, indirect ray bundles, i.e. ray bundles diffracted and scattered on the specimen details, are of major importance in addition to the so-called direct ray bundles. The higher the proportion of indirect bundles of rays (aperture), the more realistic the ABBE microscopic image will be.

The cone of light emitted by the reflected light unit is reflected on a color-neutral beam splitter and then passes through the objective, which focuses the beam on the surface of the sample (so-called condenser function). The objective collects the light reflected by the specimen, and together with the tube lens it generates the microscopic intermediate image which can then be visually observed or objectively documented.

(2) Instrumentation

Reflected light brightfield viewing is possible only with the stand for reflected light.

- P&C ACR brightfield reflector module for reflected light in the reflector turret

(3) Configuring reflected light brightfield microscopy

- The microscope has been started up correctly as described in section 3.
- The microscope is switched on.
- Adjust the light intensity by turning the Intensity/LM knob (Fig. 4-19/4).
- Position a high-contrast reflected light specimen on the microscope stage.
- Swivel in the 10x objective on the nosepiece (Fig. 4-19/3).
- On the nosepiece (Fig. 4-19/6), swivel in the position with the brightfield reflector module.
- Bring the specimen into focus with the focusing drive (Fig. 4-19/5). If possible, always focus away from the specimen in order to avoid a collision between the objective and the specimen.
- Set the knurled wheel of aperture diaphragm **A** (Fig. 4-19/1) in the middle position (about half open/closed).
- Adjust the knurled wheel of the luminous-field diaphragm **F** (Fig. 4-19/2) until the luminous-field aperture is visible in the field of vision.
- Use the focusing drive to adjust the focus on the edge of the luminous-field aperture.
- Now open the luminous-field aperture until it disappears just beyond the edge of the field of view.
- To adjust the aperture diaphragm (image contrast), remove an eyepiece from the eyepiece tube and look into the tube with the naked eye, or use the auxiliary microscope instead of the eyepiece. This functions only with sufficiently reflective specimens.

- For specimens with medium contrast characteristics, set the aperture diaphragm with the knurled wheel (Fig. 4-19/1) to between 2/3 and 4/5 of the exit pupil diameter of the objective.

In most applications, this aperture diaphragm setting provides optimal contrast at almost ideal resolution, and is therefore the best compromise for the human eye.

- Then reinsert the eyepiece, adjust the focus with the coaxial coarse and fine focusing knobs and adjust the brightness to the reflected light specimen. Readjust aperture stop diameter after each objective change.

	NOTE
Never use the aperture diaphragm for controlling image brightness. Use the Intensity/LM knob (Fig. 4-19/4) for illumination intensity!	

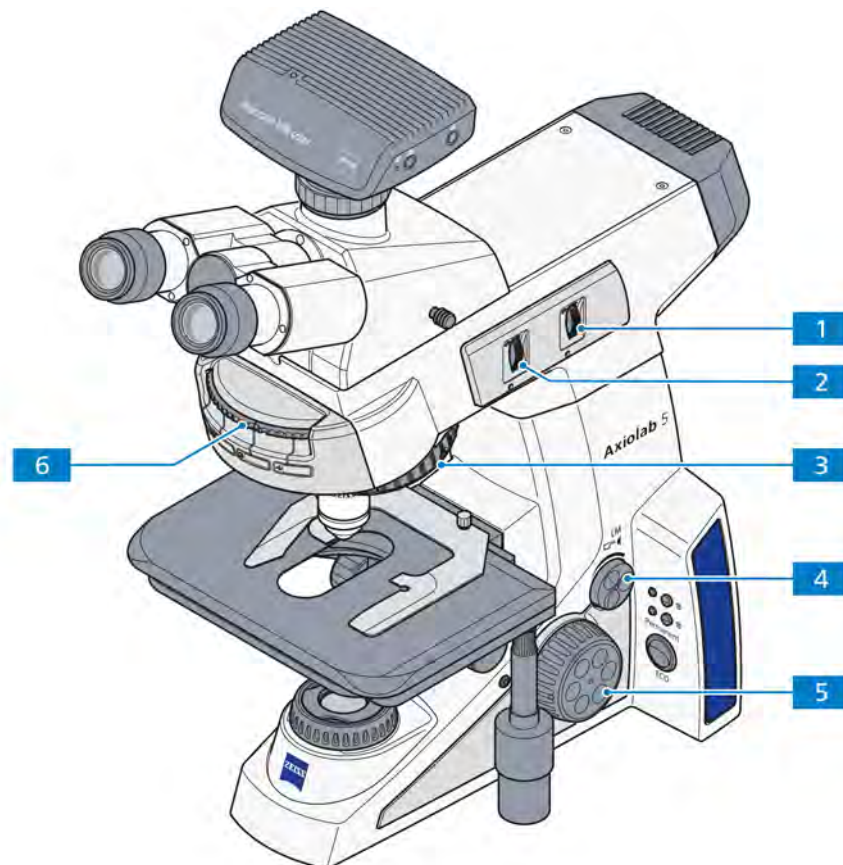

- 1 Knurled wheel of aperture diaphragm A
- 2 Knurled wheel of luminous-field diaphragm F
- 3 Nosepiece
- 4 Intensity/LM knob
- 5 Focusing drive
- 6 Reflector turret

Fig. 4-19 Microscope settings in reflected light brightfield microscopy

4.3.2 Configuring reflected light darkfield microscopy

(1) Application

Reflected light darkfield microscopy is used for examining incompletely reflecting surfaces with different degrees of reflectivity (ideal reflected light brightfield specimens), i.e. with scratches, ruptures, pores or other disruptions to the even surface. All these light-scattering details light up brightly in the darkfield, whereas the even surface remains dark.

(2) Instrumentation

Observations in the reflected light darkfield can be made only on Axiolab 5 microscopes for reflected light.

- Epiplan-Neofluar, EC Epiplan-Neofluar, Epiplan objectives with the additional designation “HD”
- ACR P&C darkfield reflector module for reflected light

**NOTE**

The stand for reflected light is equipped with a built-in darkfield stop.

(3) Configuring the reflected light darkfield

- Adjust the microscope as described in section 4.3.1 for the reflected light brightfield. In order to avoid reflexes, the displayed luminous-field aperture should be located slightly beyond the edge of the field of view.
- If used, remove the 6x20mm compensator.
- Swivel in the objective position with the darkfield objective (HD) on the nosepiece.
- If necessary, swivel in the darkfield reflector module on the reflector turret.
- Completely open the aperture diaphragm and switch off or remove the neutral filter as necessary.
- Place the specimen on the stage and sharpen the image.

4.3.3 Configuring reflected light polarization – Proof of bireflectance and reflexion pleochroism

(1) Application

Reflected light polarization is a further contrasting method for cut surfaces of mineral ore, coal, ceramic products, certain metals and alloys. Depending on the orientation of the crystals and specimen details, the cut surfaces often react differently when reflected in linear polarized light

The illumination light is linearly polarized by the polarizer before passing through the objective onto the specimen surface, where it is reflected. Here the beam parts experience path differences depending on the structure and polarization of optical rotations which, when passing through the analyzer, are displayed in different shades of gray. The gray can be converted into a color contrast with the aid of a compensator equipped with a lambda plate.

With objectives of very low magnification, a rotatable lambda/4 plate arranged in front of the objective (Antiflex cap) permits the reflections to be eliminated even with "dark" specimen surfaces, which otherwise would be unavoidable.

(2) Instrumentation

Observations in the reflected light darkfield can be made only on Axiolab 5 microscopes for reflected light.

- Pol rotary stage
- Epiplan-Neofluar Pol, EC Epiplan-Neofluar Pol, Epiplan Pol objectives
- C DIC/DIC/TIC ACR P&C or DIC/Pol ACR P&C or DIC Red I ACR P&C reflector module or Pol ACR P&C reflector module in reflector turret
- Analyzer slider D, fixed or lambda compensator, 6x20mm or Lambda/4, 6x20mm

(3) Configuring reflected light polarization

- Adjust the microscope as described in section 4.3.1 for the reflected light brightfield.
- Swivel the P&C (for DIC or Pol) reflector module on the reflector turret into the beam path and insert the analyzer slider (or lambda compensator or lambda/4 compensator) into the 6x20mm slot.
- Insert a specimen, adjust the desired magnification level, focus and observe the specimen in the polarization contrast now present while turning the Pol rotary stage.

A specimen is bireflective when the details display differences in brightness and color which change when the stage is rotated.

For samples with low bireflectance it is advisable to use the rotatable analyzer equipped with a lambda plate.

Pleochroism can be detected when the color of the specimen changes when the stage is rotated (reflected light polarizer turned on, analyzer turned off).

4.3.4 Setting reflected light fluorescence

(1) General principle

The reflected light fluorescence method is used to show fluorescent substances in typical fluorescence colors in high contrast. The light originating from a high-performance illuminator in a reflected light fluorescence microscope passes through a heat protection filter to an excitation filter (bandpass). The filtered, short-wavelength excitation beam is reflected by a dichroic beam splitter and is focused on the specimen above the objective. The specimen absorbs the short-wave radiation before emitting longer-wave fluorescence radiation (Stokes' Law). This radiation is then captured from the image side by the objective and passes through the dichroic beam separator. Finally, the beams pass through a band elimination filter (longpass/bandpass) which only permits the long-wave radiation emitted by the specimen to pass through.

The spectra of the excitation and the band-elimination filters must match very closely. They must be inserted in a reflector module FL P&C together with the respective dichroic beam splitter.

Only powerful LEDs are supplied as FL excitation light sources in the Axiolab 5 program with the following options:

LED module 385nm for Axio	423052-9593-000
LED module 470nm for Axio	423052-9573-000
LED module 505nm for Axio	423052-9562-000
LED module 565nm for Axio	423052-9602-000
LED module 625nm for Axio	423052-9522-000.

(2) Instrumentation

Observations in reflected light fluorescence can be made only on Axiolab 5 microscopes for reflected light and reflected light fluorescence.

- Recommended objectives: EC Plan-Neofluar or Fluor (UV excitation)
- LED modules for FL excitation (installed in FL stand)
- FL P&C reflector modules equipped with respective filter sets
- Fluorescence protection shield

(3) Configuring reflected light fluorescence

The adjustment of reflected light fluorescence is facilitated by starting with an objective of average magnification, e.g. EC Plan-Neofluar 20x/0.50, and a specimen of high fluorescence. Demonstration samples can also be used for the start-up.

	<p>NOTE</p> <p>If the lambda compensator used for the transmitted light polarization method is still in its slot above the nosepiece, it must be removed before configuring reflected light fluorescence.</p>
---	--

- Slide the fluorescence protection shield (Fig. 4-20/8) into the compensator slot above the nosepiece.
- Swivel in the 20x/0.50 EC Plan-Neofluar objective on the nosepiece (Fig. 4-20/2).
- Initially set transmitted light illumination by pushing the **TL** button (Fig. 4-20/5).
- If necessary, turn the condenser turret (Fig. 4-20/7) to the **BF** position for transmitted light brightfield (or phase contrast if using a Ph objective) and seek the specimen detail to be examined.
- Adjust the light intensity by turning the Intensity/LM knob (Fig. 4-20/3) and focus (Fig. 4-20/6).
- On the reflector turret (Fig. 4-20/9), select the FL P&C reflector module with the desired fluorescence filter combination (depending on the excitation mode) and swivel it into the beam path.
- Use the LED selection knob (Fig. 4-20/1) to swivel the desired LED (UV, B or G) into the beam path.

	<p>ATTENTION</p> <p>To avoid dazzling when switching between the LEDs, the brightness should be reduced slightly beforehand.</p>
---	---

	<p>NOTE</p> <p>When switching among the three LEDs, the current brightness setting is adopted.</p>
---	---

- Switch on reflected light illumination by pushing the **RL** button (Fig. 4-20/4).
- Adjust the light intensity for reflected light by turning the Intensity/LM knob (Fig. 4-20/3).
- Finally, sharpen the image of the specimen.

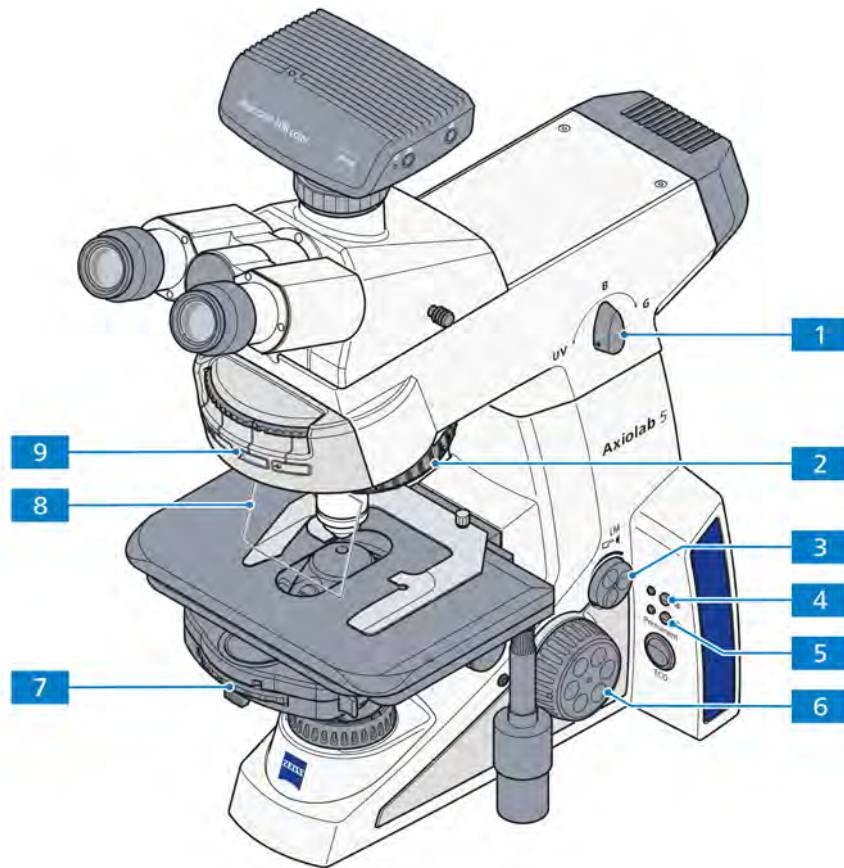

- 1 LED selection knob for swiveling in the LED UV (385 nm) or LED B (475 nm) or LED G (555 nm)
- 2 Nosepiece
- 3 Intensity/LM knob
- 4 Reflected light button (RL)
- 5 Transmitted light button (TL)
- 6 Focusing drive
- 7 Condenser turret
- 8 Fluorescence protection shield
- 9 Reflector turret

Fig. 4-20 Components for reflected light fluorescence

5 CARE, FUSE REPLACEMENT AND SERVICE

5.1 Instrument care

The only care required for the Axiolab 5 is as follows:

- Switch the device off after each use and put the protective cover on (protects against dust and moisture).
- Do not set the instrument up in a humid environment (max. humidity \leq 75%).
- Cover all open tubes with dust caps.
- Remove dust and loose dirt on visible optical surfaces using a fine brush, blower brush, cotton wool bud, optical paper or cotton cloth.
- Remove water-soluble dirt (coffee, cola, etc.) by breathing on it and wiping with a dust-free cotton cloth or a moistened cloth. A mild cleaning agent may be added to the water.
- Remove stubborn, oily or greasy dirt (immersion oils, fingerprints) using cotton wool buds or a dust-free cotton cloth and optical cleanser L.
This cleaning agent is made of 90 vol% petroleum ether and 10 vol% isopropyl alcohol (IPA). The components are also known by the following names:
Petroleum ether: surgical spirit, benzine
Isopropanol alcohol: 2-propyl alcohol,
dimethylcarbinol,
2-hydroxypropane

Clean the optical surfaces with circular movements, starting from the middle and working outward to the edges. Exert only slight pressure on optical surfaces.



ATTENTION

Do not use acetone to clean the front lens of the Pol condenser.

Please comply with the following guidelines if the microscope is to be used in a hot and humid climate:

- Keep the instrument in bright, dry and well-aired rooms, with humidity \leq 75%; in particular, sensitive parts such as objectives and eyepieces should be kept in special dry closets.

Precision optical instruments are always susceptible to mold if they are kept and used under the following conditions:

- If the relative humidity $>$ 75% over periods exceeding three days at temperatures between +15 °C and +35 °C.
- if they are set up in dark rooms without sufficient ventilation.
- if there are dust and fingerprints on optical surfaces.

5.2 Instrument maintenance

5.2.1 Checking the instrument

- Ensure compliance with the specified line voltages.
- Check the power cable and the plug for possible damage.
- If any damage is observed, turn the instrument off and secure it against inadvertent restarts immediately. Call in a qualified professional to remedy the problem.

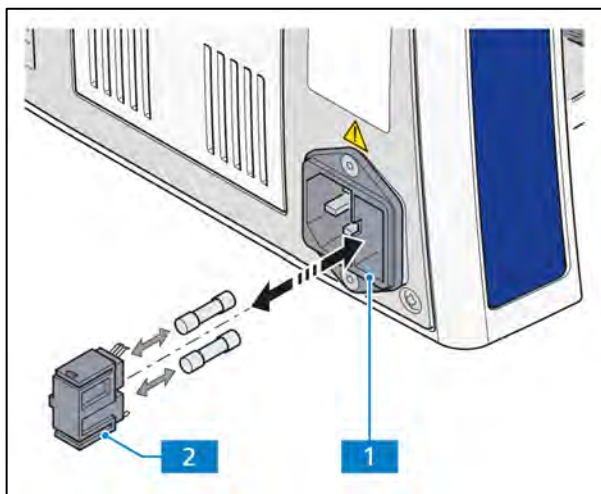

Fig. 5-1 Replacing the fuses in the stand

5.2.2 Replacing the fuses in the stand



CAUTION

Always disconnect the instrument from the power supply before replacing fuses.

If the fuses fail, the reason must first of all be ascertained and technical problems properly remedied.

The fuse box is located at the back of the microscope. It is combined with the power supply plug and contains two type **T 3.15 A/H /250 V** fuses.

- Disconnect the microscope from the power supply
- Remove the fuse holder (Fig. 5-1/2) by pulling it to the front. Use a small screwdriver for this purpose if necessary.
- Remove the fuses from the fuse holder and replace with new fuses.
- Push the fuse holder back into the fuse box (Fig. 5-1/1) until it engages.
- Connect the power plug.

5.3 Troubleshooting

5.3.1 Microscope

Problem	Cause	Solution
No illumination light after switching on the microscope.	Nosepiece and/or reflector turret are not engaged to defined positions.	Move the nosepiece and/or reflector turret to the left or right to engage the nosepiece and/or reflector turret to defined positions. Then restart the microscope.
Shadows or inhomogeneous image brightness in the field of view; the field is not entirely visible.	The vis/phot push-pull rod/shift knob on the photo tube is not in the correct functional position (intermediate position).	Move the vis/phot push-pull rod/shift knob to the correct functional position (end position).
	Nosepiece with objective not engaged in click-stop.	Push in nosepiece with objective until it engages.
	Condenser not correctly adjusted.	Set the condenser correctly (adjustment, centering); see p. 81 ff.
	Aperture diaphragm not correctly adjusted.	Set the aperture diaphragm correctly (opening); see p. 81 ff.
	Luminous-field aperture not correctly adjusted.	Set the luminous-field diaphragm correctly (aperture); see p. 81 ff.
	The filter has not been inserted correctly in the filter mount.	Insert filter correctly in the filter mount.
Low resolving power and poor image contrast.	Aperture diaphragm not correctly adjusted.	Set the aperture diaphragm as per 2/3 rule or the specimen features; see p. 81 ff.
	The condenser has not been correctly focused and front lens 0.9 not swiveled in/out correctly.	Focus the condenser and swivel front lens 0.9 in or out correctly; see p. 81 ff.
	Wrong cover glass thickness for transmitted light objectives corrected for 0.17 mm cover glass thickness.	Use standard cover glass with a thickness of 0.17 mm.
	Specimen slide placed upside down.	Turn the specimen slide over; the specimen side should be on top.
	Use of no or non-specified immersion oil with immersion objectives.	Use immersion oil 518 N or 518 F from ZEISS
	Air bubbles in immersion oil.	Repeat oiling procedure with fresh oil.
	Immersion oil on the front lens of a dry objective.	Clean the front lens of the dry objective.
	Correction setting is not set to the proper thickness of the cover glass.	Adjust the correction setting ring to the correct cover glass thickness.
	Dirt or dust on the optical surfaces of objectives, eyepieces, condensers or filters.	Clean the respective optical components.

Problem	Cause	Solution
Asymmetric image sharpness, e.g. one side is sharp, one is side blurred.	Condenser is not correctly adjusted.	Adjust the condenser correctly; see p. 81 ff.
	Nosepiece is not engaged in its locking position.	Engage the nosepiece in its locking position (click-stop).
	The specimen has not been fixed on the mechanical stage.	Insert and fix correctly in the specimen holder.
Distinct focus differences when changing the objective.	Focusable eyepieces are not adjusted correctly or a Pol eyepiece was used in a binocular tube without upright image.	Adjust the focusable eyepieces according to the vision defect, see p. 79.
	Objective is not screwed in all the way.	Screw the objective in to the stop.
	Tube lens is not mounted, or mounted unnecessarily.	Mount the tube lens or remove it, as appropriate.
Left and the right field of view cannot be brought together in one image.	Eyepiece distance (inter-pupillary distance) is not adjusted correctly.	Adjust the inter-pupillary distance correctly; see p. 79.
	Focusable eyepieces are not adjusted correctly.	Adjust the focusable eyepieces according to the vision defect, see p. 79.
Eye fatigue when using the microscope.	Eyepiece distance (inter-pupillary distance) is not adjusted correctly.	Adjust the inter-pupillary distance correctly; see p. 79.
	Focusable eyepieces are not adjusted correctly.	Adjust the focusable eyepieces according to the vision defect, see p. 79.
	Image brightness is unacceptable.	Adjust the lamp voltage or insert a conversion filter.
	Binocular tube is optically/mechanically misaligned.	Call in service personnel for check/repair.
Dirt or dust in the field of view.	The condenser has not been correctly focused and front lens 0.9 not swiveled in/out correctly.	Focus the condenser and swivel front lens correctly in or out; see p. 81 ff.
	Opening of the aperture diaphragm is too small.	Set the aperture diaphragm as per 2/3 rule or the specimen features; see p. 81 ff.
	Dirt or dust on optical surfaces of objectives, eyepieces, condensers, filters or specimens.	Clean the optical surfaces of the soiled components, see p. 119.

Problem	Cause	Solution
LED/halogen lamp does not light up although the switch is in the On position.	Power plug is not plugged into the mains outlet.	Insert the plug into the mains outlet. Ensure that the outlet and instrument have the same voltage.
	Lamp is not installed.	Install lamp, see p. 64.
	Lamp is defective.	Replace lamp, see p. 64.
	Fuses are defective.	Replace fuses, see p. 120.
	Installed electrical equipment may be defective.	Call in the service personnel to check components and replace if necessary, see p. 126.
	No voltage from the power socket.	Use a different mains power socket.
Halogen lamp flickers, illumination intensity is not stable.	Halogen lamp is reaching the end of its service life.	Replace the halogen lamp, see p. 64.
	Power cable is not installed properly or is damaged.	Install the power cable properly or replace it.
	Pins of the LED/halogen lamp are not properly inserted in the socket.	Insert the pins of the lamp correctly, see p. 64.
No light in eyepiece	The system is in ECO mode	Turn the Intensity/LM knob clockwise to wake up the system.
	The light intensity too low	Turn the Intensity/LM knob clockwise to increase the light.
	The light was turned off by pressing the corresponding RL/TL button	Press the RL or TL button according to the corresponding indicator (green).
	Wrong or missing reflector module (reflected light in use)	Check the reflector turret and make sure the correct reflector is in use.

5.3.2 Axiocam 202/208

When the microscope is in use with Axiocam 202/208

Problem	Cause	Solution
LED indicator is off.	The camera is not drawing power via the USB (Commercial Micro-D) cable.	Make sure the microscope is powered on and connect the USB (Commercial Micro-D) cable to the stand.
	USB cable is not connected to a certified power supply unit.	Connect the camera to a running PC. Requirements: 5 V DC with at least 1000 mA at output.
	USB cable is not suitable.	Use the USB cable provided in the original package.
Firmware update does not function.	For an update, a USB stick must be inserted and the firmware to be updated must be saved to the root folder on the USB stick.	Insert a formatted USB stick with firmware in the root folder with at least 200 MB free memory space. Comply with the instructions enclosed with the firmware update.
Date/Time is wrong on the camera.	Date/time is not set correctly.	Date/time can be set in OSD under Operating System setting.
	The buffer battery has no charge.	Contact service
The image has severe noise.	The amplification (gain) is set too high.	Open 3D noise reduction; reduce the gain.
	The exposure time is set too high.	Open 3D noise reduction; reduce the exposure time.
	The light intensity is set too low.	Open 3D noise reduction; increase the light intensity.
The image is too dark or too bright.	Automatic exposure time has not been activated.	Activate auto exposure or manually adjust the exposure time and gain so that the settings are suitable for the current light situation.
The camera forgets the settings (e.g. manual white balance, resolution) if the power supply is disrupted.	Settings are not stored.	5 seconds is required for the settings to be automatically stored.
Monitor connected via HDMI does not display an image.	The camera is not delivering a signal, or signal is not compatible with the monitor.	Ensure that the camera has been switched on for at least 30 seconds and the LED indicator is blue. Check the plug connections on the camera and monitor.
The camera cannot be recognized by the PC.	Camera is not recognized by the Windows drive.	Make sure camera is powered on and re-connect the USB cable to the PC.

Problem	Cause	Solution
The image appears distorted on the full-screen monitor.	The image aspect ratio is 16:9. The monitor may be set to a different aspect ratio and causes the distortion.	Set the monitor aspect ratio to 16:9.
The image is blurred on the screen but the sample is in focus through eyepieces.	Focus plane of the camera is different from that of the eyepieces.	Make sure the sample is focused correctly through eyepieces and adjust the camera adapter until image is in focus on the monitor.
The camera otherwise behaves abnormally.	The camera may have been put into an unintended state.	Press the factory reset button on the camera.

5.4 Maintenance and repair

Repairs of mechanical, optical or electronic components inside the instrument and electrical components of Axiolab 5 microscopes may be performed only by ZEISS service staff or specially **authorized** personnel.

To ensure optimal configuration and trouble-free function of your microscope over a longer period of time, we recommend that you enter into a service/maintenance agreement with ZEISS.

For subsequent orders or when service is required, please get in touch with your local ZEISS representative.

If servicing is required, please contact your local representative or

Carl Zeiss Microscopy GmbH
Carl-Zeiss-Promenade 10
07745 Jena, Germany

microscopy@zeiss.com
www.zeiss.com/microscopy



Carl Zeiss Suzhou Co., Ltd.
Modern Industrial Square 3-B, No.333
XingPu Road SIP
215126 Suzhou, China

5.5 Firmware update

For updating the firmware, please use the following link for downloading the latest version:

<https://www.zeiss.com/microscopy/us/downloads.html>

6 APPENDIX

6.1 List of abbreviations

AC	Alternating current
ACR	Automatic Component Recognition
AF	Width across flats
B/BF	Brightfield
BL	Bertrand lens
CSA	Canadian Standards Association
C DIC	Differential Interference Contrast in circular polarized light
CGT	Cover glass thickness
D/DF	Darkfield
d	Diameter (e.g. filter)
DC	Direct Current
DIC	Differential Interference Contrast
DIN	Deutsches Institut für Normung (German Institute for Standardization)
EC	European Community
EN	Euronorm (European standard)
Ergo	Ergonomic/Ergonomics
FL	Fluorescence
foc.	focusable
GW	Suitability for glasses wearers
HDMI	High Definition Multimedia Interface
IEC	International Electrotechnical Commission
IP	Internal protection (through housing)
ISO	International Standardization Organization
L	Left (coaxial knurled knob left on mechanical stage)
LED	Light emitting diode
LM	Light manager
OSD	On-screen display
Ph	Phase contrast
phot	photographic
PL	Plan
Pol	Polarization
P&C	Push&Click
R	Right (coaxial knurled knob to right of mechanical stage)
RL	Reflected light

SLR	Single Lens Reflex
T	Slow (type of fuse)
TIC	Total interference contrast in circular polarized light
TL	Transmitted light
UL	Underwriters Laboratories
UV	Ultraviolet
VAC	Volt AC
vis	visual

6.2 Index

	Page
A	
Ametropia	80
Analyzer	28, 95, 102, 103, 107
Analyzer slider	90, 91
Aperture diaphragm	30, 32, 40, 82
Auxiliary microscope	54
Axiocam	43, 49, 72
Axiolab 5 stand, Bio-TL	22
Axiolab 5 stand, Bio-TL/FL	24
Axiolab 5 stand, Mat-TL/RL	32
Axiolab 5 stand, Pol-TL	26
Axiolab 5 stand, Pol-TL/Conoscopy	28
Axiolab 5 stand, Pol-TL/RL	30
B	
Bertrand lens	28, 98, 109
Binocular photo tube	36
Binocular tube	35, 53
Bireflexion	115
Birefringence	89, 101
Bright field	81, 112
C	
Cable holder	22, 24, 26, 28, 30, 32
Care	119
Carrying handle	22, 26, 28
Centering screw for condenser	22, 24, 26, 28, 30, 32
Checking the instrument	120
Circular polarization contrast	95, 107
Coarse adjustment	22, 24, 26, 28, 30, 32
Color glass carrier	88
Color tables	93
Comfortable ergo tube	24
Components	35
Optional	73
Standard	51
Condenser	21, 22, 24, 26, 28, 30, 32, 40, 62, 75, 81, 84
Condenser carrier	21, 22, 24, 26, 28, 30, 32, 62
Condenser, darkfield	63
Conoscopy	28, 98, 109
Contrasting techniques	15
Control and functional elements	21, 24, 26, 28, 30, 32, 35
Co-observer unit	73
D	
Dark field	114
Dark field stop	84
Default factory settings	78
Default setting	79
Depolarizer	89

Description of the instrument	15
Determining crystal character.....	98, 109
Diaphragm.....	88
Dimensions	17
Display elements	34
Drive length	57
E	
Ergo photo tube.....	37
Ergo tube.....	37
Eyecups	55
Eyeglass protection ring.....	55
Eyeiece reticle.....	54, 80
Eyeieces	22, 24, 26, 28, 30, 32, 54
F	
Field diaphragm	88
Filter carrier.....	21
Filter holder.....	73
Filter mount	40
Filter slider	41
Filter slider, reflected light.....	30, 32
Fine adjustment.....	22, 24, 26, 28, 30, 32
Firmware update	126
Fluorescence	24, 116
Focusing drive	22, 24, 26, 28, 30, 32, 83
Friction adjustment.....	58
Front lens.....	62, 81
H	
Height stop on condenser carrier	83
I	
Illumination and contrast methods.....	81, 112
Indicator light.....	22, 24, 26, 28, 30, 32
Industrial property rights.....	132
Instrument care	119
Instrument maintenance.....	120
Instrument safety	8
Intended use	15
Interface diagram	20
Inter-pupillary distance	79
K	
Keys.....	34
KÖHLER	81, 84
L	
LED illumination	21
LED illuminator.....	64, 67
LED selection knob	24
Light intensity	22, 24, 26, 28, 30, 32
Light Manager.....	22, 24, 26, 28, 30, 32
Light Manager function	77

Light sources	18
Low-power system.....	41, 74
Luminous-field diaphragm	22, 24, 26, 28, 30, 32, 82
M	
Maintenance	120
Materials stand.....	32
Mechanical stage.....	22, 24, 32, 38, 39, 57
Microscope stages	38
Mode switch Permanent/ECO.....	28, 30
Modulator disk	75
Mounting the Axiocam	72
N	
Nosepiece.....	22, 24, 26, 28, 30, 32, 42, 55, 61, 81
O	
Objective centering.....	61
Objectives.....	55, 60
On/off switch	22, 24, 26, 28, 30, 32, 76
Operating modes.....	43
Operation.....	79
OSD	50
P	
Path difference	94
Permanent/ECO mode switch.....	22, 24, 26, 32
Phase contrast	87
Photo tube	22, 26, 28, 30, 32, 35, 53
Pinhole diaphragm.....	54
Polarization	26, 28, 30, 89, 98, 109, 115
Polarization direction	91, 103
Polarizer	21, 42, 73, 90
Polarizer D, fixed, removable.....	26, 28, 30
Power cord.....	52
Power supply.....	75
R	
Reflected light	30, 32, 112, 114, 115, 116
Reflected light (RL) button.....	24, 30, 32
Reflected light bright field.....	112
Reflected light dark field	114
Reflected light fluorescence	24, 116
Reflected light illumination.....	30, 32
Reflected light polarization.....	115
Reflector module	21, 56
Reflector turret.....	41, 56
Reflexion-pleochroism.....	115
Replacing the fuses.....	120
Reticle	54
Rotary stage Pol.....	26, 28, 30, 39, 59, 60, 89, 91, 95, 101, 103, 107
S	
Service	126

Setting up	51
Slot	22, 24, 26, 28, 30, 32
Snap button	22, 24, 26, 28, 30, 32
Specimen guide	39, 59
Specimen holder	38, 39
Specimen holding plate	39
Stage	21
Stage carrier	22, 24, 26, 28, 30, 32, 57, 59, 60, 62
Stage clip	59
Stand	21
Stand models	21
Stands keys	34
Start-up	51
Switching on/off	76
T	
Technical data	17
Tool	52
Tool kit storage	22, 24, 26, 28, 30, 32
Transmitted light	22, 24, 26, 28, 30, 32, 81, 87, 89, 98, 109
Transmitted light (TL) button	24, 30, 32
Transmitted light illumination	24, 26, 28
Transmitted light illuminator	22, 30, 32
Transmitted light phase contrast	87
Troubleshooting	121
Tube	21, 22, 24, 26, 28, 30, 32, 54
U	
Unpacking	51
V	
Vertical adjustment of condenser	22, 24, 26, 28, 30, 32
Viewing height	19, 79
W	
Warning label	12
Warranty	14
Weight	17

6.3 Industrial property rights

Instruments, instrument components and methods described in this manual are protected by the following patents:

- see label on microscope stand

6.4 System overview

See the following pages.

